

INSTRUCTION MANUAL

ASSEMBLY

OPERATION AND MAINTENANCE

FOR TC10 -S CARTS

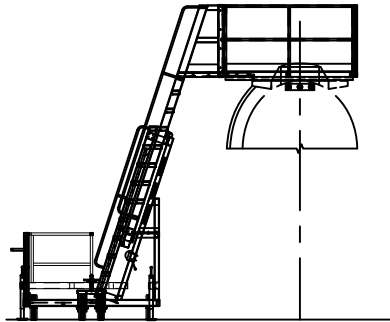

TC10-TR-S

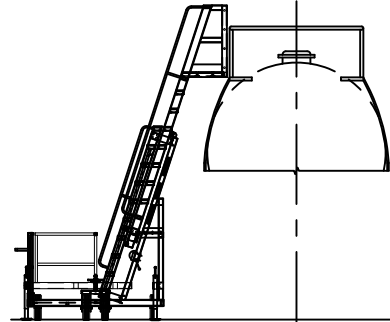

TC10-S

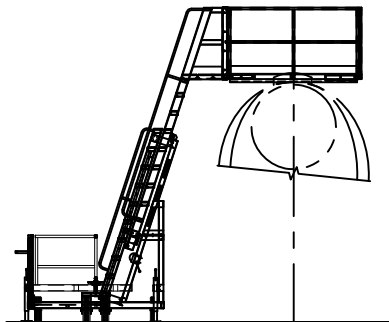

TC10-TR-S

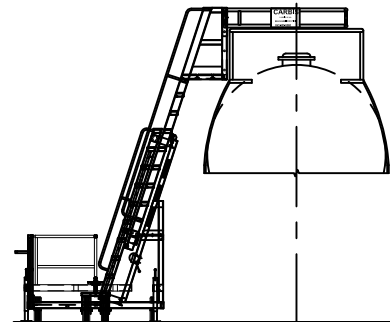

TC10-RC-S

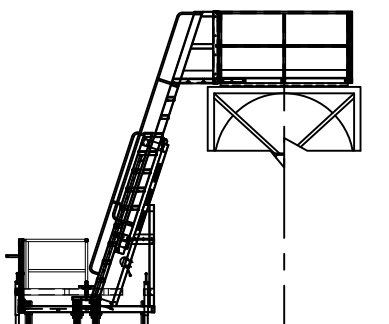

TC10-TR-S

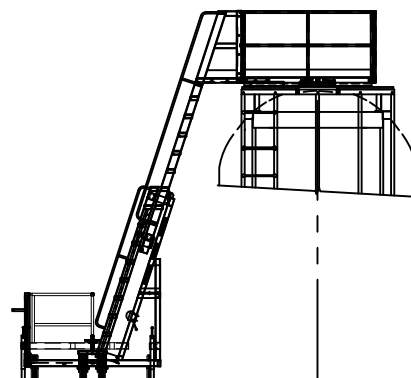

TC10-TR-S



Proven Solutions in Safe Access and
BEYOND

P.O. BOX 6229
FLORENCE, SC 29502-6229
800-845-2387
FAX: (843) 662-1536
WEB SITE: WWW.CARBIS.NET

TABLE OF CONTENTS

- READ THIS FIRST
- CAUTIONS AND WARNINGS
- INTRODUCTION AND SAFETY
- PRODUCT DESCRIPTION
- ASSEMBLY
- OPERATION
- MAINTENANCE
- EXTENDED INSPECTION ADDENDUM
- DRAWINGS & SPECIFICATIONS
- ADDENDA

READ THIS FIRST!

This Installation, Operation, and Maintenance manual is considered an integral part of the Carbis equipment to which it applies. It is the Owner's responsibility to insure that personnel who operate and maintain the Carbis equipment receive comprehensive training in the operation and maintenance of the equipment, including adjustments where required. Operating and Maintenance personnel must also be familiar with the basic characteristics of the equipment so as to avert errors that might result in equipment damage or personnel injury. It is also the Owner's responsibility to insure that maintenance activities are appropriately documented, including any abnormal operating condition and its associated root cause evaluation, followed by corrective actions implemented to eliminate recurrence.

Aging of equipment and associated service life-limiting variables such as corrosion, fatigue, wear, etc., must be remedied during maintenance periods to preclude operational failure.

While this manual provides guidance to operating personnel in the matter of safe operation and recommended practices, it is not and cannot be a substitute for well-trained operations personnel. For a successful and trouble-free operation, great reliance must be placed on the knowledge, background, and experience of the operating personnel, with this manual serving as a guide. The warranty on the equipment is automatically voided if the information contained in this manual is disregarded, whether inadvertent or willful.

CAUTIONS AND WARNINGS

IMPORTANT: READ THIS MANUAL CAREFULLY BEFORE UNPACKING OR INSTALLING CARBIS EQUIPMENT. FAILURE TO FOLLOW THESE GUIDELINES MAY RESULT IN PERSONAL INJURY OR DAMAGE TO EQUIPMENT.

WARNING: CORRECT VEHICLE POSITIONING AND PROPER DEPLOYMENT OF CARBIS EQUIPMENT IS IMPERATIVE TO ITS FUNCTION. INCORRECTLY POSITIONED VEHICLES OR IMPROPER USE OF THIS EQUIPMENT INCREASES THE RISK OF INJURY AND/OR DEATH. CARBIS EQUIPMENT IS DESIGNED TO FUNCTION ONLY AS DESCRIBED IN THE MANUAL AND DEPICTED ON THE DRAWINGS. **IT IS THE SOLE RESPONSIBILITY OF THE OWNER TO ENSURE PROPER USE OF CARBIS EQUIPMENT.**

WARNING! BEFORE ACCESSING CARBIS EQUIPMENT A VEHICLE MUST BE IN THE CORRECTLY SPOTTED POSITION AND THE CARBIS EQUIPMENT PROPERLY DEPLOYED. FAILURE TO DO SO CAN RESULT IN INJURY OR DEATH.

WARNING! PERSONNEL MUST NOT ACCESS CARBIS EQUIPMENT DURING ANY CONTROLLED OPERATION. TO DO SO CAN RESULT IN INJURY OR DEATH.

WARNING! NONESSENTIAL PERSONNEL MUST STAY CLEAR OF CARBIS EQUIPMENT DURING ANY CONTROLLED OPERATION. FAILURE TO DO SO CAN RESULT IN INJURY OR DEATH.

WARNING! OPERATOR MUST BE CERTAIN THAT NONESSENTIAL PERSONNEL ARE CLEAR OF CARBIS EQUIPMENT DURING ANY CONTROLLED OPERATION. FAILURE TO DO SO CAN RESULT IN INJURY OR DEATH.

WARNING! PERSONNEL MUST NOT OPERATE CARBIS EQUIPMENT WHILE OCCUPYING VEHICLE. TO DO SO CAN RESULT IN INJURY OR DEATH.

WARNING! CARBIS EQUIPMENT MUST NEVER BE FORCED BY ANY MEANS TO OVERCOME ANY SEEN OR UNSEEN OBSTACLE OR OBSTRUCTION. DOING SO CAN RESULT IN INJURY OR DEATH.

WARNING! ALL CARBIS EQUIPMENT MUST BE PROPERLY SUPPORTED AND SECURED BEFORE ACCESSING. THE TC10 IS ONLY SELF-SUPPORTING WHEN THE LOCKING PINS ARE FULLY ENGAGED; OTHERWISE, THE UNIT MUST REST ON A VEHICLE.

INTRODUCTION & SAFETY

This product has been inspected and meets Carbis' Quality Control Standards. It is important that the information contained in this manual be reviewed before operating the unit, including the following:

- Inspect equipment upon delivery for shipping damage or loose bolts. All fastening hardware that has been factory installed has been done so to remain tight; if any fastening hardware, whether factory or field installed, has been loosened, it is

imperative that it be tightened before using the product.

- **WARNING:** This equipment can conduct electricity. Any grounding that may be required is to be performed per your company's safety codes.
 - Appropriate Personnel Protective Equipment (PPE) such as gloves, safety glasses, safety shoes, etc., should be worn at all times during operation of this equipment.
 - Before activating the equipment always insure that all other equipment and personnel are clear of components during controlled operations.
 - Only qualified personnel in good physical condition trained in the proper operation of this equipment should be permitted to operate it.
 - Check that all warning/caution/notice safety placards/sign/decals are clearly visible, legible, and in good repair. Operating personnel must be familiar with the contents of such placards, signs, and decals.
-
- **ATTENTION: AVOID PROBLEMS WITH STAINLESS STEEL BOLTS.** Keep bolts and nuts free of grime and others contaminants that may get into threads. Lubricate stainless steel bolts and nuts prior to tightening. Avoid the use of impact speed wrenches. If one is used, a slower speed will allow heat to dissipate as the connection is tightened.

STANDARD TC10 **PRODUCT DESCRIPTION**

1. GENERAL

- The TC10 tank car and rail car access system is a versatile, universal, side-mounted or inline cart and ladder system for accessing a variety of truck and rail car vehicles, and includes optional enclosures such as cages, platforms, and knock down handrails as reflected by the following drawings (refer to specific drawing that applies):
 - TC10: Ladder Platform on Rail Car - Inline
 - TC10-S: Ladder Platform on Rail Car – Side Mounted
 - TC10-RC: Ladder Platform and Rail Car Cage on Rail Car - Inline
 - TC10-RC-S: Ladder Platform and Rail Car Cage on Rail Car – Side Mounted
 - TC10-TR: Ladder Platform and Knock Down ISO Platform on Hopper Car - Inline
 - TC10-TR-S: Ladder Platform and Knock Down ISO Platform on Hopper Car – Side Mounted
 - TC10-TR: Ladder Platform and Knock Down ISO Platform on Tank Truck – Inline
 - TC10-TR-S: Ladder Platform and Knock Down ISO Platform on Tank Truck – Side Mounted
 - TC10-TR: Ladder Platform and Knock Down ISO Platform on ISO Truck – Inline
 - TC10-TR-S: Ladder Platform and Knock Down ISO Platform on ISO Truck – Side Mounted

- The TC10 requires assembly before use; see the next section, **ASSEMBLY**, for instructions.
- The TC10 design load capacity is 500 lbs. When used as a stand-alone unit without the addition of any optional enclosure, fully engaged locking pins must support the monolithic ladder fly section and ladder platform. With the addition of any optional enclosure, the system can be supported by a vehicle or by the locking pins.
- The TC10 meets or exceeds OSHA regulations as we interpret them.
- The TC10 working range height from grade level to the underside of the platform is from a minimum of 9'-10" to a maximum of 16'-6".

2. MECHANICAL EQUIPMENT

- The basic TC10 consists of a galvanized steel base and a telescoping aluminum ladder fly section with handrails on the sides and a ladder platform at the top.
- The inline base incorporates an aluminum fixed ladder bolted to a frame support cart, a rear set of foam-filled pneumatic tires, and dual foam-filled pneumatic tires at the front that are integral with a tow bar/steering mechanism.
- The side-mounted base is the same as the inline base except that the foam-filled tires are on one side and the dual foam-filled tires and tow bar/steering mechanism are on the opposite side.
- Leveling jacks are mounted on the rear and front outrigger bars of the steel base.

- Steel counterweight bars are fixed to the front counterweight frame.
- All walk surfaces are slip resistant.
- The uprights of the top ladder platform incorporate bolt holes for mounting the following optional aluminum safety enclosures:
 - Rail car cage
 - Truck and rail car knock down ISO platform and handrail system that includes a partial walk surface at the ladder platform, with the remaining area within the handrails open
 - Truck knock down ISO platform and handrail system that includes a partial walk surface at the ladder platform and an optional rotating platform on the outboard handrail.
- Wire rope attached to the inside bottom of the telescoping ladder, and running over pulleys on the cart frame, is attached to a hand winch mounted on the frame support; the hand winch is the source of power for raising and lowering the telescoping ladder platform.
- Pinholes located on 6” centers along the fixed ladder rails each side are for pinning the telescoping ladder platform, which makes the unit self-supporting.

ASSEMBLY

SEE THE FOLLOWING DRAWINGS:
STANDARD TC10 ASSEMBLY LAD-ASSY
TC10 ASSEMBLY TC10MAN2

APPLICABLE DRAWING FROM PRODUCT DESCRIPTION LIST

- Check that all of the parts shown on the drawings have been received in undamaged condition, including the hardware items.
- Required Bolt Tensioning for Structural Connections
 - Calibrated Wrench Method – A325 bolts only
 - Bolt Dia Min Bolt Tension (kips)
 - 1/2" 12
 - 5/8" 19
 - 3/4" 28
 - 7/8" 39
 - 1" 51
 - Turn of Nut Method – A325 bolts only
 - Bolt Length Turns*
 - Up to 4X Dia 1/3 turn
 - 4X Dia to 8X Dia 1/2 turn
 - Over 8X Dia Use calibrated wrench Method.

* The starting position of the turns is after the bolt has reached a “snug tight” condition. Tolerance should be +/- 30 degrees.

1. ASSEMBLY

- A qualified erector should perform the assembly and installation of the Carbis equipment in conformity with industry standards and local building code requirements, and in accordance with the most recent industry practices for safe rigging. The procedures outlined in this section describe safe and practical sequences. Any deviation preferred by the erector/rigger must be in conformance with the above-referenced standards, codes, and practices. See Assembly Drawings for Carbis-supplied components and hardware lists. NOTE: Some parts may be preassembled.

1. Where applicable, assemble the ISO knock down platform and handrail system, including the rotating panel as required.
2. Where applicable, assemble the platform or cage to the top of the telescoping ladder.
3. Assemble the aluminum handrails to the telescoping ladder platform.
4. Assemble the aluminum fixed ladder to the front of the steel base.
5. Assemble screw jacks to the ends of each steel outrigger bar.
6. Run the wire rope from the hand winch up over the two block pulleys on the steel base down between the steel base and the extension ladder. Loop the thimble through the hole in the bracket mounted on the inside of the bottom step of the telescoping ladder.
7. Install wire rope clips per the following steps:

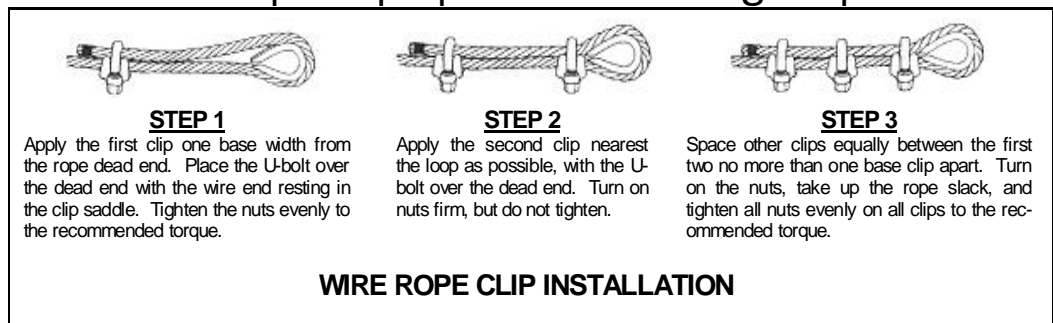

OPERATION

- Visually inspect the equipment before each use. Never access damaged or broken components.
- Do not let the unit come in contact with live electrical wires; do not handle live electrical wires while standing on the unit or while in contact with the unit.
- Do not use this unit on slippery surfaces.

- Make certain that walk surfaces are free of product that would interfere with the safe, slip-resistant feature of the walk surface.
 - Do not overload the unit; the ladder is designed for one person.
 - The unit is self-supporting when the locking pins are employed and fully engaged; otherwise, the unit must rest on a vehicle before accessing. NOTE: without the addition of any optional enclosure, the locking pins must support the unit.
 - Make certain that the ladder is in the lowest stored position and that the leveling jacks are in the horizontal stored position whenever the unit is being transported.
 - Before operation, visually inspect the area between the equipment and the vehicle for any obstruction that would impede movement or create a tripping hazard. Remove any obstruction before operating the equipment.
 - Before operation, be certain that no personnel are in the path of equipment movement.
 - No personnel are to ride any component while it is in motion.
 - Never attempt to operate the system with personnel occupying the equipment or the vehicle.
1. Remove wheel chocks (if used) or raise the leveling jacks that were used to store the unit.
 2. With the ladder in the lowest stored position, move the unit into approximate position at the vehicle.
 3. Using the hand winch, extend the ladder and platform full height to be certain the unit will clear any point on the vehicle.

4. Move the unit closer to the vehicle so that the ladder platform/enclosure is in the approximate desired area.
5. The following step options are determined by operational requirements, and they dictate whether the unit is self-supporting or not. If the unit does not include an optional enclosure, step a) must be followed:
 - a. Extend or retract the ladder as needed for optimum position with the ladder pinholes aligned. Make certain that no part of the unit is resting on any vehicle component subject to damage when a load is applied. Insert the locking pins, making certain they are fully engaged to insure the unit is self-supporting, or:
 - b. Lower the ladder/enclosure so that the protective bumpers on the underside of the system rest on the vehicle. Make certain that the bumpers or any part of the enclosure are not resting on any vehicle component subject to damage when a load is applied. As long as the locking pins are not engaged, the unit must rest on the vehicle, and it is not self-supporting.
6. Lock the leveling jacks in the vertical position and extend them to disengage the wheels from the ground.
7. **IMPORTANT:** If the unit is not self-supporting, the ladder and platform/enclosure will need to be lowered again to rest on the vehicle as noted in Step 5b.
8. Face the ladder when climbing up or down; maintain center of gravity, i.e., belt buckle between ladder side rails.

9. Maintain a firm grip; use both hands when climbing.
10. When finished with the work, remove any tools from the cage area, platform, or ladder stand.
11. Face the ladder to descend, maintain center of gravity, and firmly grip the ladder with both hands when climbing back down.
12. When finished with the unit, remove the locking pins (if used) and extend the ladder and platform full height to clear any point on the vehicle when the wheels engage the ground and the unit is moved away from the vehicle.
13. Retract the leveling jacks to engage the wheels with the ground, and rotate the jacks to the horizontal stored position.
14. Move the unit clear of the vehicle.
15. Lower the ladder to its lowest position for transport.
16. Steer the unit to its stored location. Chock the wheels or extend at least two jacks (front or back) to disengage the associated wheels from the ground to keep the unit immobile.
17. If the unit is to be towed, connect the tow bar to the towing vehicle and do not exceed a tow speed of 5 mph.
18. If the unit will not move when pushed or pulled, or if the ladder will not extend or retract when using the hand winch, or if any leveling jack will not function as needed, discontinue use and contact

Maintenance immediately. Failure to follow instructions, or any attempt to dislodge obstructions may result in severe injury or death.

MAINTENANCE

1. Before servicing the TC10, ensure that the equipment is properly “locked and tagged” per safety regulations.
2. Visually inspect the assemblies before each use. Replace any damaged parts. If component replacement requires any disassembly, refer to the **ASSEMBLY** section of this manual to restore the system to its operational status. Monthly inspection of the assemblies is recommended as a minimum. Harsh atmosphere and/or heavy use may dictate more frequent inspection and maintenance.
3. Clean all walk surfaces that would otherwise interfere with the slip-resistant feature of the walk surface. Frequency of cleaning is dictated by the frequency of product build-up on the walk surfaces.
4. All fastening hardware that has been factory installed has been done so to remain tight. If any fastening hardware, whether factory or field installed, has been loosened, it is imperative that it be tightened before using the equipment.
5. Check that all moving parts are functioning properly.
6. Keep assemblies clean and free from grease, oil, mud, snow, wet paint, and any other slippery material.

7. Never make repairs of damaged or missing parts; replace missing parts only with approved equal parts.
8. Lubricate the wheel bearings with a lithium-based grease. See addenda for lubrication of winch.
9. Wire rope and associated components maintenance procedures:
 - Refer to the hand winch manufacturer's literature to let out the wire rope sufficient to slip the rope away from the sheaves for inspection.
 - Never inspect a wire rope by passing bare hands over the rope body.
 - Clean the rope with a cloth or wire brush to inspect thoroughly.
 - Check the entire length of the wire rope and replace if any distortion such as kinking, crushing, unstranding, birdcaging, main strand displacement, or core protrusion is found.
 - Replace any end connection that is severely corroded, cracked, bent, worn, or broken per the following:



STEP 1

Apply the first clip one base width from the rope dead end. Place the U-bolt over the dead end with the wire end resting in the clip saddle. Tighten the nuts evenly to the recommended torque.



STEP 2

Apply the second clip nearest the loop as possible, with the U-bolt over the dead end. Turn on nuts firm, but do not tighten.



STEP 3

Space other clips equally between the first two no more than one base clip apart. Turn on the nuts, take up the rope slack, and tighten all nuts evenly on all clips to the recommended torque.

WIRE ROPE CLIP INSTALLATION

- Repair or replace sheaves containing corrugated grooves, flat spots, or broken flanges.
- Lubricate wire rope immediately after cleaning, using a cloth or sponge soaked with a lubricant

that is free from acids and alkalis, has sufficient adhesion to remain on the rope, a viscosity that will allow penetration between the wires and strands, has a high film strength, and anti-corrosion additives. CAUTION: Extreme care must be taken during hand lubrication due to the potential hazard to personnel.

- CAUTION: Per the hand winch manufacturer's maintenance caution, do not get oil or grease on the hand winch friction discs; this could allow the load to slip or fall.
- Slip wire rope back over the sheaves and refer to the hand winch manufacturer's literature to pull the cable in.

10. For any assistance, replacement parts, comments, or questions, please call Carbis' Customer Service Department at 1-800-845-2387. Please have your model number, serial number, or drawing number available to expedite your request.

TC10 EXTENDED INSPECTION **ADDENDUM**

The low maintenance nature of the TC10 does not require any more stringent inspection than that noted in the Maintenance section of this Instruction Manual. However, at the request of some customers whose internal programs require annual inspections, the following extended inspection procedure can be performed during an annual inspection:

1. Remove all tires and leveling jacks.
2. Thoroughly clean all surfaces in preparation for visual inspections. Especially clean all walk surfaces of product that would otherwise interfere with the safe, slip-resistant feature of the walk surface.
3. Check all welds on all surfaces of all components, including those ordinarily hidden from view, to be certain there are no weld cracks.
4. Thoroughly check all surfaces of all components, including those ordinarily hidden from view, for any signs of corrosion.
5. Check all bolted connections. First, make certain that none can be hand loosened; then check the connections again using a wrench to make certain they are securely snug.
6. Thoroughly check the foam-filled tires for excessive tread wear. Remove all debris caught in the treads. If any tire has been punctured, remove the object and repair the tire externally. Replace any tire whose condition is beyond repair or excessively worn.
7. Install tires and lubricate wheel bearings.
8. Check each leveling jack for corrosion, excessive wear, and ease of operation. Replace any leveling jack whose condition so warrants.
9. Install leveling jacks.
10. Check hand winch per manufacturer's recommendations noted in this Instruction Manual.
11. The wire rope maintenance procedures as described in the Maintenance section of this instruction manual can be performed as part of an annual inspection procedure.

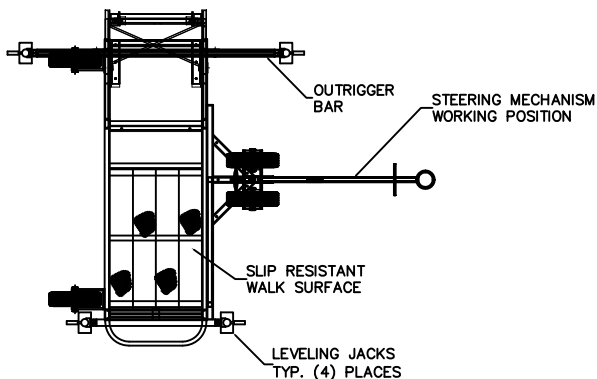

PLAN VIEW
LADDER & PLATFORM NOT SHOWN
FOR CLARITY

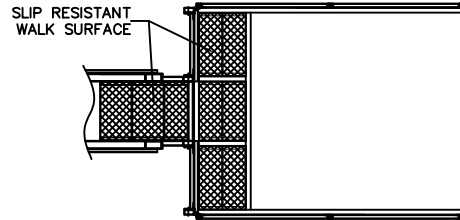

PLAN VIEW
LADDER PLATFORM & TRUCK PLATFORM SHOWN
(FOR TANK TRUCK, HOPPER TRUCK, HOPPER CAR, & ISO TRUCK APPLICATIONS)
RAIL CAR CAGES AVAILABLE AS AN OPTION

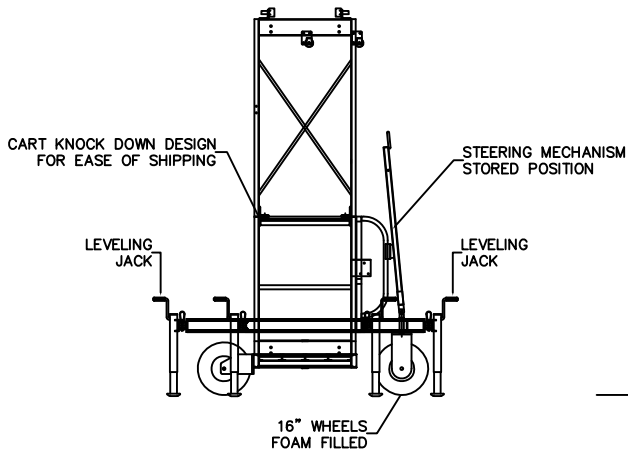

FRONT VIEW
LADDER & PLATFORM NOT SHOWN
FOR CLARITY

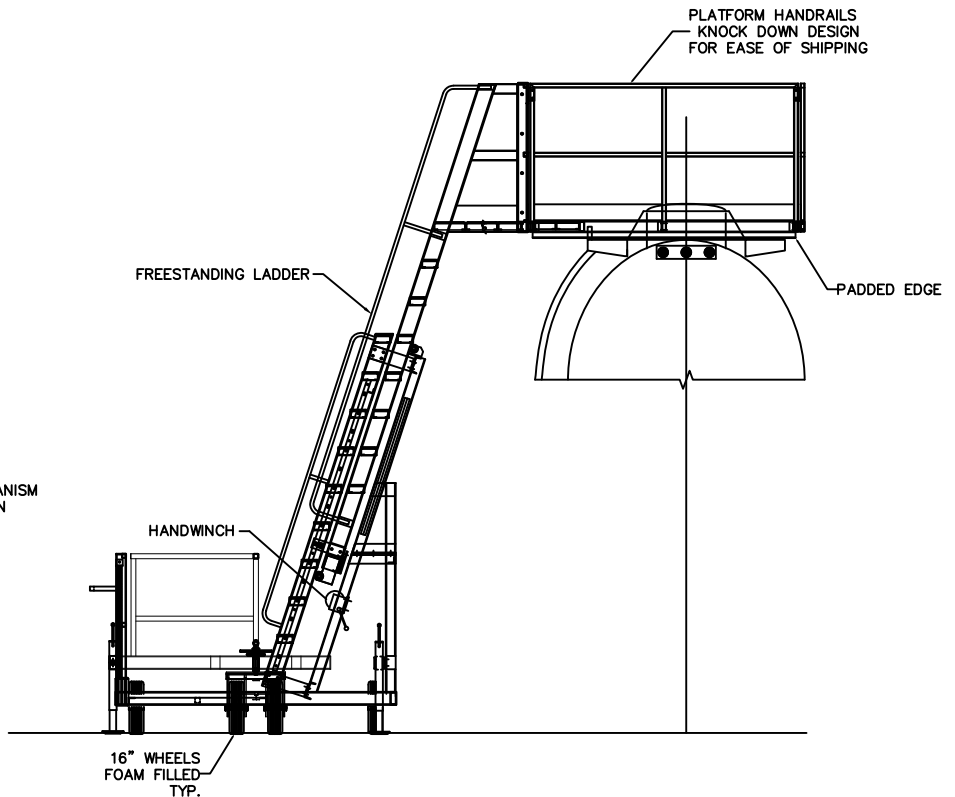

SIDE ELEVATION VIEW
SHOWN IN WORKING POSITION

SPECIFICATIONS			
MODEL	UNEXTENDED HEIGHT	EXTENDED HEIGHT	WEIGHT LBS.
TC10	9'-6"	16'-6"	1600

THE FREE STANDING TC10-S MEETS OR EXCEEDS OSHA REGULATIONS AS WE INTERPRET THEM.

NOTES:

- 1) LADDER & PLATFORM TO BE ALUMINUM CONSTRUCTION.
- 2) BASE TO BE GALVANIZED STEEL CONSTRUCTION.
- 3) WALK SURFACE ON BASE & PLATFORM TO BE SLIP RESISTANT.
- 4) LADDER IS ADJUSTABLE FROM 9'-10" TO 16'-6" FROM GRADE TO BOTTOM EDGE OF PLATFORM IN 6 INCH INCREMENTS
- 5) UNIT IS SELF SUPPORTING AND NEED NOT REST ON A VEHICLE
WHEN LOCKING PINS ARE FULLY ENGAGED PRIOR TO ACCESSING.
- 6) 500 LB CAPACITY

TC10 -S CART ASSEMBLY DRAWING

NOTE:
 PLATFORM TO LADDER CONNECTION ALSO TYP.
 FOR RAIL CAR CAGE TO LADDER.

- (1) $\frac{1}{2}$ " X 3" LG. HEX BOLT
- (2) $\frac{1}{2}$ " FLAT WASHERS
- (1) $\frac{1}{2}$ " S/S STOP NUT
- PLATFORM TO LADDER CONNECTION (8) PLACES

- (1) $\frac{1}{2}$ " X 4" LG. HEX BOLT
- (2) $\frac{1}{2}$ " FLAT WASHERS
- (1) $\frac{1}{2}$ " S/S STOP NUT
- PLATFORM TO LADDER CONNECTION (2) PLACES

LADDER
 (FLY SECTION)

NOTE:
 SOME PARTS MAY BE
 PREASSEMBLED.

TRUCK & ISC
 PLATFORM

- (2) $\frac{1}{2}$ " X 2" LG. HEX BOLT
- (2) $\frac{1}{2}$ " FLAT WASHER
- (2) $\frac{1}{2}$ " HEX NUT
- PER BRACKET TO LADDER (4-PLACES)

LADDER
 (BUTT SECTION)

- (1) $\frac{1}{2}$ " X 2" LG. HEX BOLT
- (1) $\frac{1}{2}$ " FLAT WASHER
- (1) $\frac{1}{2}$ " HEX NUT
- PER CART CONNECTION (TYP.3-PLACES EA. SIDE)

SIDE CART

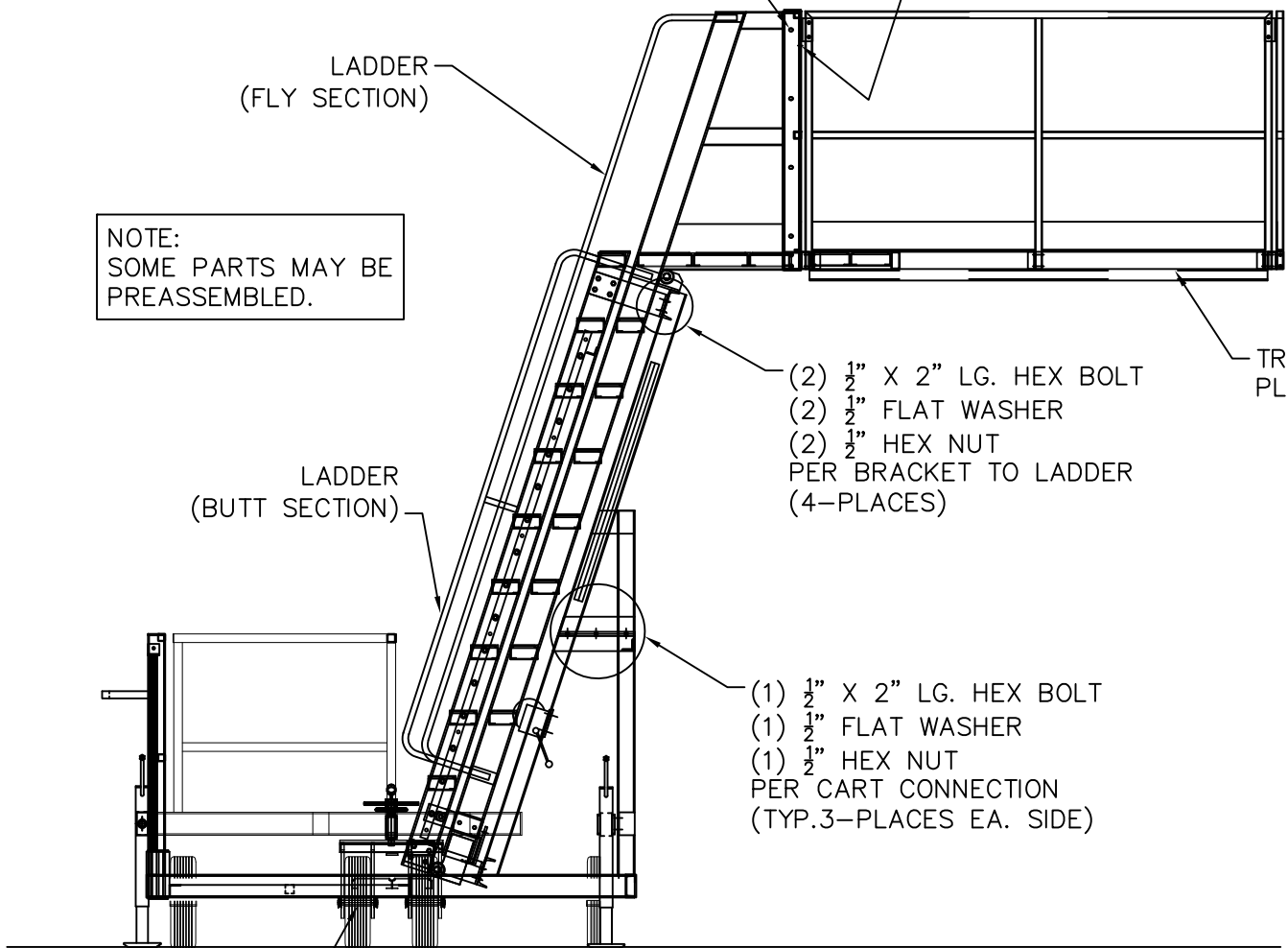

HANDRAIL TO ISO PLATFORM ASSEMBLY ONLY

LOCKNUT TIGHTENING REQUIREMENTS

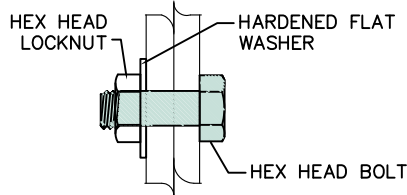

* BOLTS FITTED WITH LOCKNUTS OF $\frac{3}{8}$ " DIA. OR SMALLER SHOULD BE TIGHTENED TO A TORQUE OF 60 IN-POUNDS.

PART NO	QTY	DESCRIPTION	MAT'L
HR-1	1	LEFT FRONT HANDRAIL	A
HR-2	1	RIGHT FRONT HANDRAIL	A
HR-3	2	SIDE HANDRAIL	A
HR-4	1	BACK HANDRAIL	A

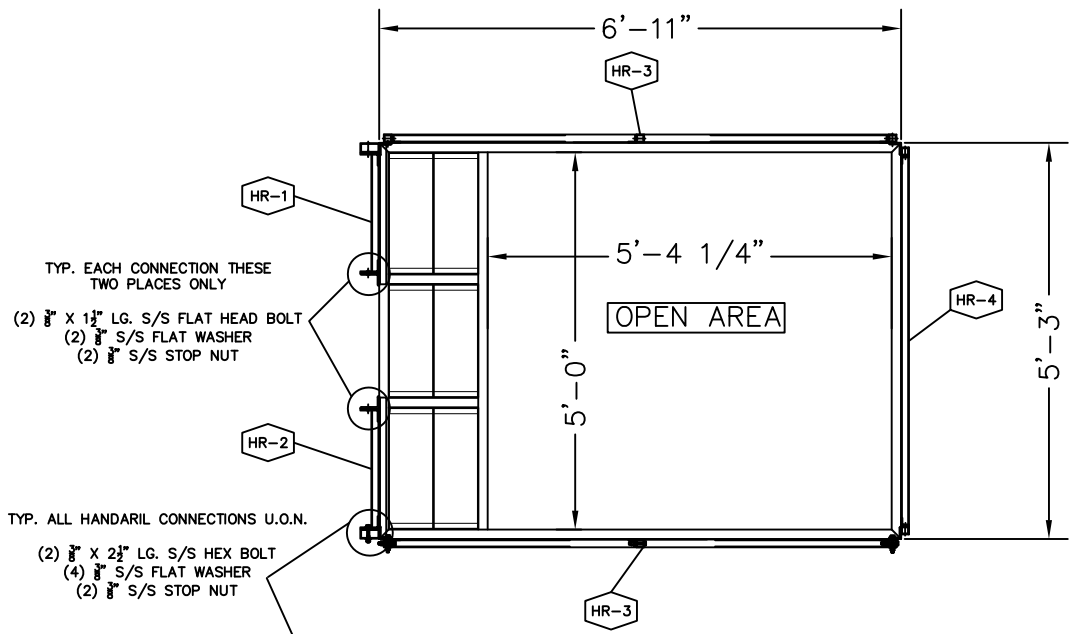

PLAN VIEW OF PLATFORM AND HANDRAILS

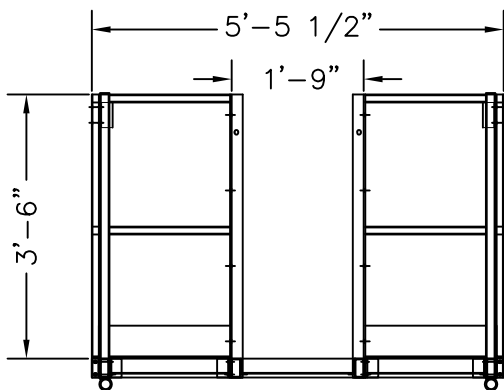

FRONT VIEW OF PLATFORM AND HANDRAILS

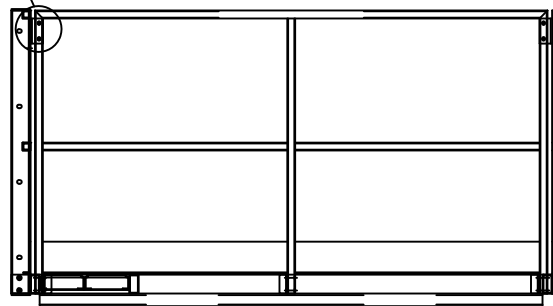

SIDE VIEW OF PLATFORM AND HANDRAILS

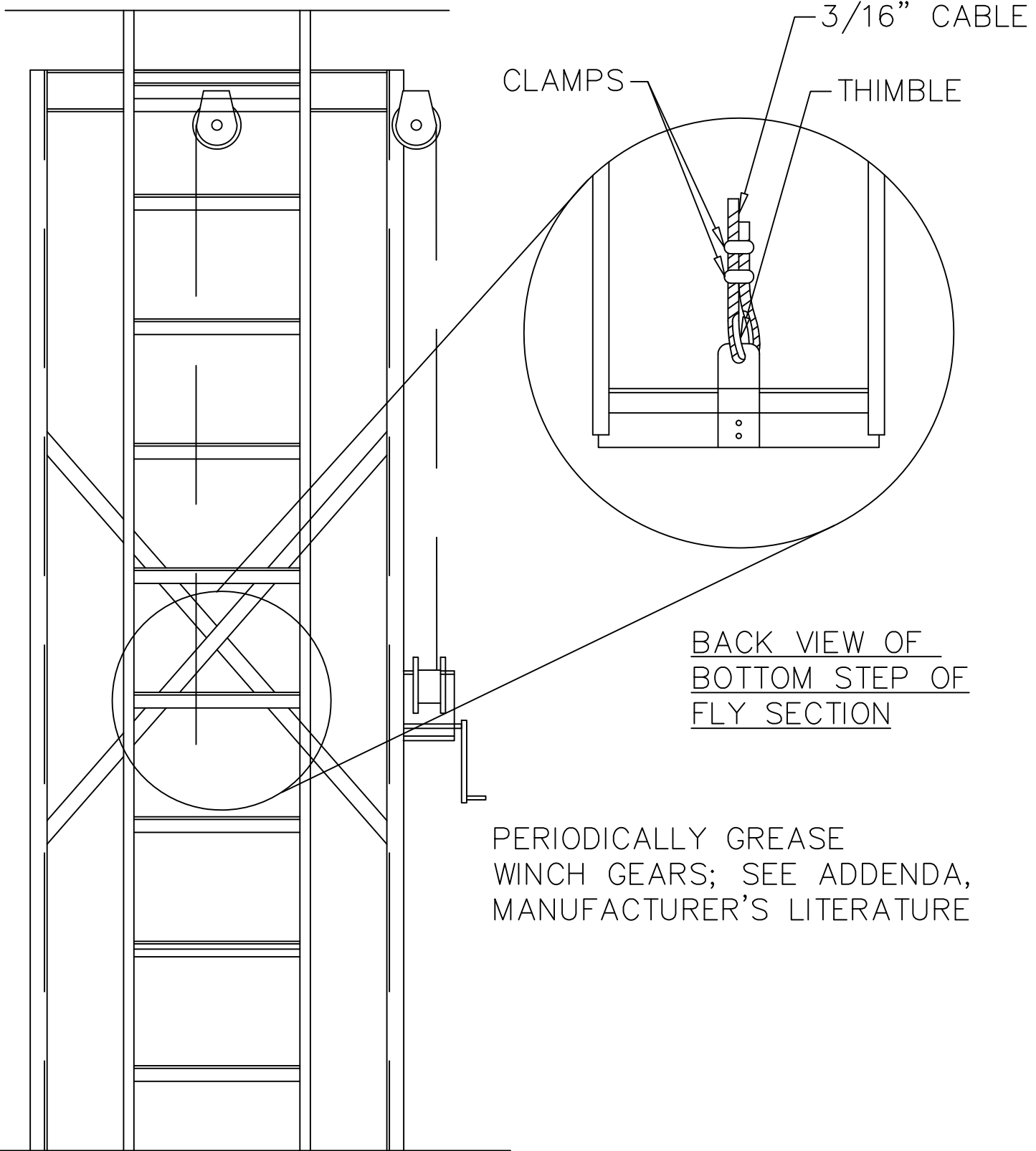

3/16" CABLE

CLAMPS

THIMBLE

BACK VIEW OF
BOTTOM STEP OF
FLY SECTION

PERIODICALLY GREASE
WINCH GEARS; SEE ADDENDA,
MANUFACTURER'S LITERATURE

FRONT VIEW OF TC10-S



BRAKE WINCHES

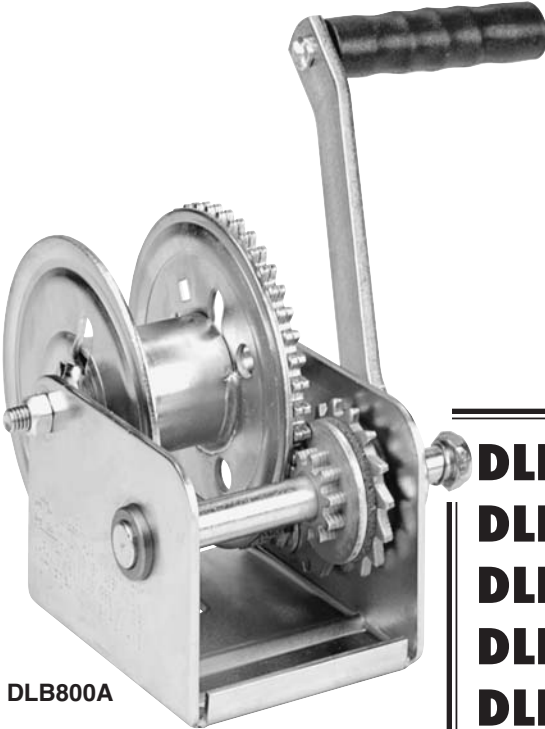

DLB800A

DLB350A
DLB350AG
DLB800A
DLB800AG
DLB1200A
DLB1200AG
DLB1500A
DLB1500AG
DLB2000AG
DLB2500A

MANUFACTURED BY



DUTTON-LAINSON
COMPANY *SINCE 1886*

MADE IN U.S.A.

451 West 2nd St. • Hastings, NE 68902-0729 • TEL: 402-462-4141 • FAX: 402-460-4612
Web Site www.dutton-lainson.com

Dwg. No. 206306K 1/08

ISO 9001: 2000 REGISTERED Q.M.S.

⚠ WARNING READ INSTRUCTIONS CAREFULLY BEFORE ATTEMPTING TO INSTALL, OPERATE OR SERVICE THIS WINCH. FAILURE TO COMPLY WITH INSTRUCTIONS COULD RESULT IN SERIOUS OR FATAL INJURY. RETAIN THESE INSTRUCTIONS FOR FUTURE REFERENCE.



IMPORTANT SAFETY INFORMATION

- This brake winch is built for multi-purpose hauling and lifting operations. It is not to be used as a hoist for lifting, supporting or transporting people, or for loads over areas where people could be present.
- Respect this winch. High forces are created when using a winch, creating potential safety hazards. It should be operated and maintained in accordance with instructions. Never allow children or anyone who is not familiar with the operation of the winch to use it. A winch accident could result in personal injury.
- Check winch for proper operation on each use. Do not use if damaged. Seek immediate repairs.
- Never exceed rated capacity. Excess load may cause premature failure and could result in serious personal injury. This winch is rated on first layer of cable on the hub. Using more layers of cable increases the load on the winch.
- Never apply load on winch with cable fully extended. Keep at least three full turns of cable on the reel.
- Secure load properly. When winching operation is complete, do not depend on winch to support load.
- Operate with hand power only. This winch should not be operated with a motor of any kind. If the winch cannot be cranked easily with one hand, it is probably over-loaded.
- If winch will be used in freezing, icy conditions, apply silicone spray to ratchet pawl and spacer items V, W, X or Y. Do not spray other brake mechanism parts.

ASSEMBLY – Thread the handle onto the winch drive shaft and be certain that a clicking noise is produced when the handle is turned clockwise. Install the spring and locknut (Items E and G) on the end of the drive shaft as shown on parts drawing. These parts may appear to serve no function, but they provide several important fail-safe features, and should not be altered or removed.

WINCH MOUNTING AND CABLE ATTACHMENT

– For maximum strength and safety, this winch should be mounted with three 3/8" bolts (M10), washers and lock washers. (See parts drawing). Using fewer bolts or alternate locations will result in damage to the winch base and the winch may malfunction.

Attach cable or rope by either method shown in sketch.

OPERATING INSTRUCTIONS – Wind cable on winch reel by turning winch handle in clockwise direction. This should produce a loud, sharp, clicking noise. The load will remain in position when the handle is released. Wind cable off the winch reel by turning winch handle counterclockwise (no noise will be produced). The load will remain in position when the handle is released, but for extra security it is recommended that the handle be turned clockwise until at least two clicks are heard. This will add extra tightness to the brake mechanism. Always satisfy yourself that the winch is holding the load before releasing the winch handle.

⚠ IMPORTANT: Sufficient load must be applied to the cable to overcome internal resistance and operate the brake properly, otherwise turning the crank handle counterclockwise will only remove the handle from the shaft – the reel will not turn. The minimum operating load

requirement is 50 lb (23 kg) for Models DLB350A, DLB350AG, DLB800A, DLB800AG, DLB1200A and DLB1200AG, 75 lb (34 kg) for DLB1500A and DLB1500AG, 175 lb (80 kg) for DLB2000AG and DLB2500A.

Models DLB805A, DLB1205A, & DLB1505A, are equipped with a lockout lever for the purpose of 'freewheeling' cable out when there is no load on the winch. To 'freewheel' cable out, simply turn the handle counterclockwise until lockout lever can be engaged behind handle hub. In this condition cable can be easily pulled from the winch drum.

⚠ WARNING: Never put winch in freewheel mode if any potential for a load on the cable exists. Engaging the lockout lever keeps the winch from stopping in the event that a load is accidentally applied.

WINCH MAINTENANCE – In order to insure maximum performance, a periodic inspection for any necessary preventive maintenance should be made. Check at least once annually and more frequently when the winch is exposed to an environment which is particularly dirty or wet. For continued smooth performance and increased life, occasionally grease gears, reel shaft and handle threads. An occasional drop of oil on the drive

shaft bearings is also recommended. If winch will be used in freezing, icy conditions, apply silicone spray to ratchet pawl and spacer items V, W, X or Y. **Note: Do not oil or grease brake mechanism items H and J.**

Keep winch in good working order. Damaged or severely-worn parts create unnecessary dangers and could result in personal injury or property damage.

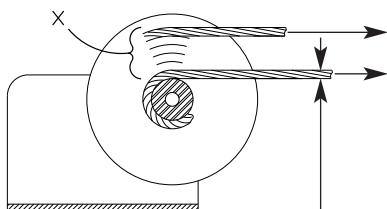

DLB350A DLB350AG	3.2:1
DLB800A DLB800AG	4.4:1
DLB1200A DLB1200AG	5.4:1
DLB1500A DLB1500AG	5.4:1
DLB2000AG DLB2500A	17.3:1

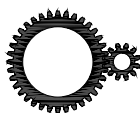

ENGLISH – EC DECLARATION OF CONFORMITY – Dutton-Lainson Company, Hastings, NE 68902-0729 U.S.A. manufactures and declares that this winch is in conformity with the essential health and safety requirements specified in The Supply of Machinery (Safety) Regulations 1992 and the provisions of The Machinery Directive (89/392/EEC). This declaration does not apply to other machinery using this winch.

DANSK – EØF OVERENSSTEMMELSESERKLÆRING – Dutton-Lainson Company, Hastings, NE 68902-0729 U.S.A. fremstiller og erklærer, at dette skraldespil er i overensstemmelse med de væsentlige sundheds- og sikkerhedsregler som er specificeret i The Supply of Machinery, Sikkerhedsregulativet af 1992, og Maskineldirektiv (89/392/EØF). Denne erklæring gælder ikke andet maskineri, der benytter skraldespillet.

SUOMI – EY:N VAATIMUSTENMUKAISUUSVAKUUTUS – Dutton-Lainson Company, osoite Hastings, NE 68902-0729, USA, vakuuttaa tämän vintturin valmistajana, että vintturin noudattava vuoden 1992 koneidontimitusäänönnösten (Supply of Machinery [Safety] Regulations) olennaisia työturveyks- ja turvallisuusvaatimuksia sekä konedirektiivin (89/392/ETY) määräyksiä. Tämä vakuutus ei koske muita laitteita, joissa vintturia käytetään.

NEDERLANDS – EG VERKLARING VAN OVEREENSTEMMING – Dutton-Lainson Company, Hastings, NE 68902-0729 VS, fabrikant, verklaart dat deze lier voldoet aan de fundamentele gezondheids- en veiligheidsisen zoals vastgelegd in de Machineryrichtlijn (89/392/EEG) en de nationale wetgeving ter uitvoering van deze richtlijn. Deze verklaring is niet van toepassing op andere machines die gebruik maken van deze lier.

FRANÇAIS – DÉCLARATION DE CONFORMITÉ CE – Dutton-Lainson Company, Hastings, NE 68902-0729 U.S.A. construit ce treuil et déclare qu'il est conforme aux exigences de sécurité et de sûreté essentielles spécifiées dans «The Supply of Machinery (Safety) Regulations 1992» (règlements de sécurité relatifs à la fourniture de machinerie) et dans «The Machinery Directive» (directive relative à la machinerie) (89/392/CEE). Cette déclaration ne s'applique pas aux autres machines utilisant ce treuil.

DEUTSCH – EU-KONFORMITÄTSEKTLÄRUNG – Dutton-Lainson Company, Hastings, NE 68902-0729 USA, der Hersteller der Winde, erklärt, daß das Produkt mit den grundlegenden Gesundheits- und Sicherheitsanforderungen übereinstimmt, die in den Bestimmungen zum Inverkehrbringen von Maschinen (Sicherheit) 1992 und den Bestimmungen der Maschinenrichtlinie (89/392/EWG) spezifiziert sind. Diese Erklärung gilt nicht für andere Maschinen, die diese Winde verwenden.

	X	
DLB350A, DLB350AG	10	110 lb/50kg
	1	350 lb/160kg
DLB800A, DLB800AG	9	330 lb/150kg
	1	800 lb/360kg
DLB1200A, DLB1200AG	8	551 lb/250kg
	1	1200 lb/545kg
DLB1500A, DLB1500AG	6	728 lb/330kg
	1	1500 lb/680kg
DLB2000AG	5	959 lb/435kg
	1	2000 lb/905kg
DLB2500A	5	1308 lb/593kg
	1	2500 lb/1134kg

DLB350A	1/8" (2000 lb) x 84'
DLB350AG	3mm (590kg) x 22.5m
DLB800A	3/16" (4200 lb) x 68'
DLB800AG	4mm (1080kg) x 23.0m
DLB1200A	7/32" (5600 lb) x 69'
DLB1200AG	5mm (1640kg) x 19.7m
DLB1500A	1/4" (7000 lb) x 60'
DLB1500AG	6mm (2350kg) x 15.1m
DLB2000AG	7mm (3200kg) x 8.9m
DLB2500A	5/16" (9800 lb) x 34'

ITALIANO – DICHIARAZIONE DI CONFORMITÀ ALLE DIRETTIVE DELLA COMUNITÀ EUROPEA – La Dutton-Lainson Company, con sede a Hastings, NE 68902-0729 USA, produce verricelli e dichiara che questo verricello è conforme ai requisiti essenziali di sicurezza e tutela della salute specificati nella normativa sulla sicurezza delle macchine emessa nel 1992 e nella Direttiva Macchine 89/392/CEE. Questa dichiarazione non è valida per altre macchine che utilizzino questo verricello.

NORSK – SAMSVARERKLÆRING FOR EU – Dutton-Lainson Company, Hastings, NE 68902-0729, USA, fremstiller og erklærer at denne vinsjen er i samsvar med grunnleggende helse- og sikkerhetskrav spesifisert i for sikkerhetsforskriftene i det amerikanske regelverket for maskinlevering av 1992 [The Supply of Machinery (Safety) Regulations], samt bestemmelsene i det amerikanske maskindirektivet for EØS (89/392/EEC). Denne erklæringen gjelder ikke for andre maskiner som bruker denne vinsjen.

PORTUGUÊS – DECLARAÇÃO DE CONFORMIDADE COM A CE – A empresa Dutton-Lainson Company, Hastings, NE 68902-0729, nos E.U.A., fabrica este guincho e declara que este está em conformidade com os requisitos essenciais de saúde e segurança, tal como especificados nos Regulamentos (de Segurança) para o Fornecimento de Máquinas de 1992 e como previsto na Directiva relativa a Máquinas (89/392/CEE). Esta declaração não se aplica a outras máquinas que utilizem este guincho.

ESPAÑOL – DECLARACION DE HOMOLOGACION PARA CE – Dutton-Lainson Company, de Hastings, NE 68902-0729, EE.UU., fabrica y declara que este cabrestante satisface los requisitos esenciales de salubridad y seguridad especificados en el Reglamento (de Seguridad) para Suministro de Maquinarias de 1992 y en las disposiciones de la Directriz de Maquinarias (89/392/EEC). Esta declaración no incluye los demás equipos que utilicen este cabrestante.

SVENSKA – FÖRSÄKRAN OM ÖVERENSSTÄMMELSE – Dutton-Lainson Company, Hastings, Nebraska 68902-0729 U.S.A. tillverkar och försäkrar att denna vinsch överensstämmer med de väsentliga hälso- och säkerhetskrav som specificerats i Maskineriförordningar (säkerhet) 1992 och bestämmelserna i Maskineridirektiv (89/392/EEC). Denna försäkran gäller inte andra maskiner som använder denna vinsch.

ΕΛΛΗΝΙΚΑ – ΔΗΛΩΣΗ ΣΥΜΜΟΡΦΩΣΗΣ ΕΟΚ Η Dutton-Lainson Company, Hastings, NE 68902-0729, U.S.A δηλώνει ότι κατασκευάζει το παρόν βαρούλκο σε συμμόρφωση με τις βασικές απαιτήσεις υγιεινής και ασφαλείας που προβλέπονται από τους Κανονισμούς Διάθεσης Μηχανημάτων (Ασφαλείας) 1992 και τις διατάξεις της Κοινοτικής Οδηγίας για Μηχανήματα (89/392/ΕΟΚ). Η δήλωση αυτή δεν ισχύει για άλλα μηχανήματα που χρησιμοποιούν το παρόν βαρούλκο.

Ron Hease



DLB350A & DLB350AG Winch

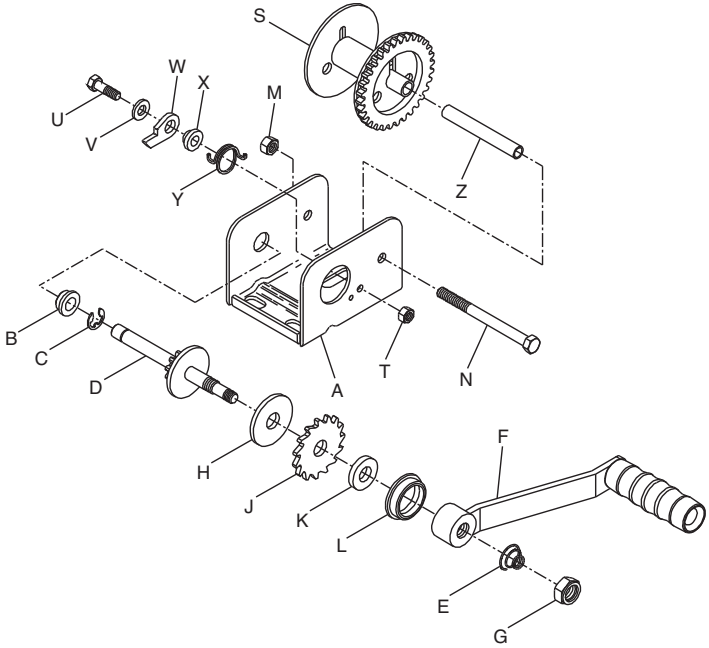

DLB800A & DLB800AG Winch

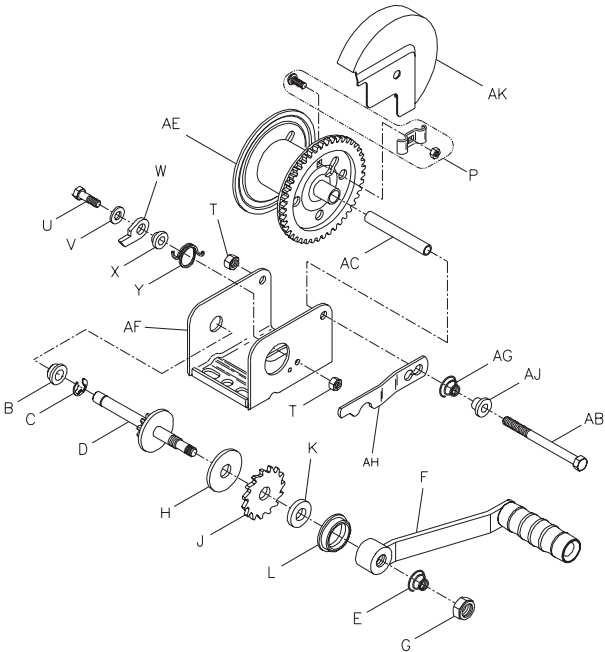



DLB1200A & DLB1200AG Winch

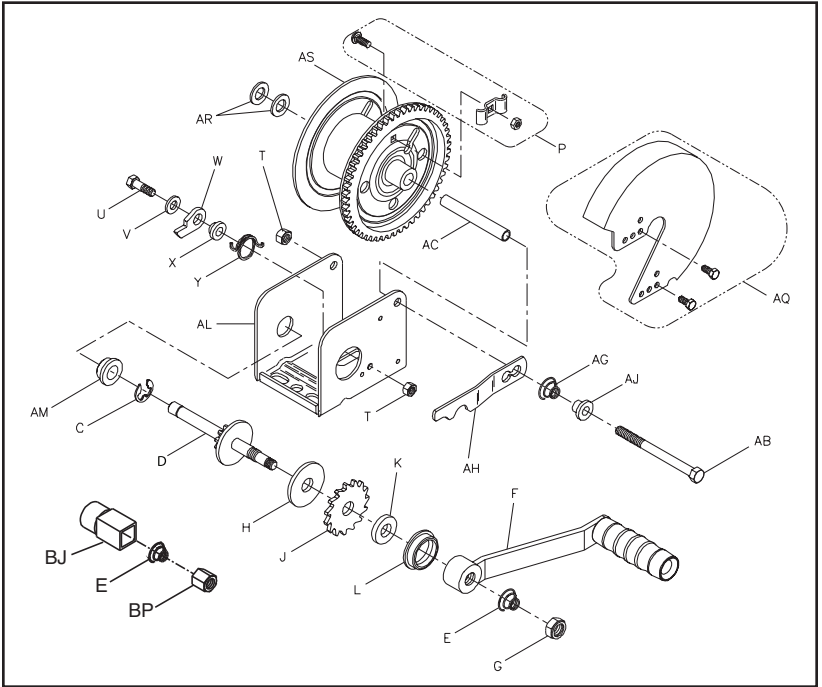

DLB1500A & DLB1500AG Winch

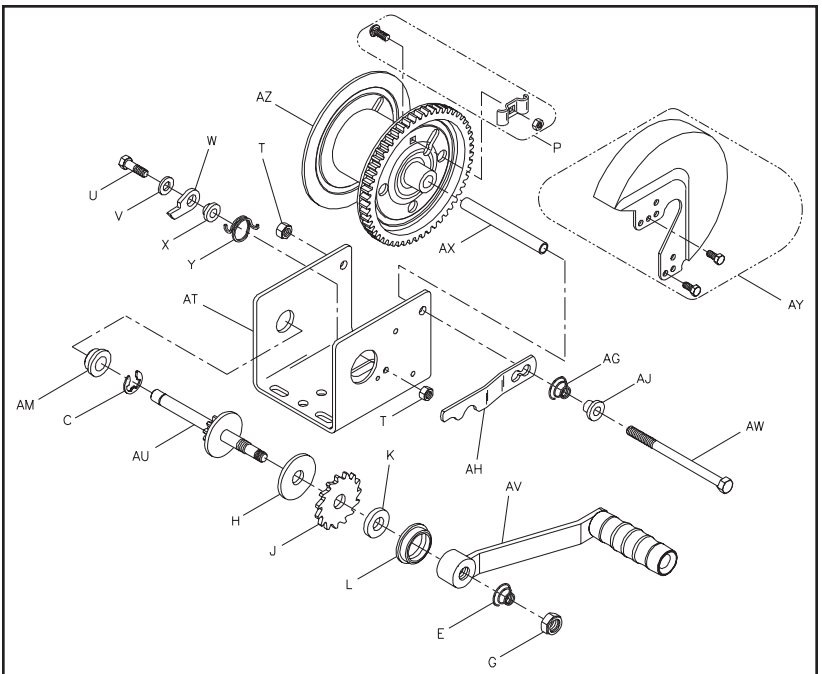

PARTS LIST

Ref	Description	Part No.
A	Base	404900*
A	Base – DLB 350AG	404945*
B	Bushing	204012
C	“E” Ring	205116
D	Drive Shaft	306061
E	Spring	204364
F	Handle – 7”	5703061
	Handle – 9-3/8”	5703103
G	Nut	205033
H	Pressure Plate	204362
J	Ratchet Wheel	404164
K	Pressure Washer	404163
L	Bushing	206328
M	Nut	205316
N	Bolt	205332
P	Rope Clamp Kit	304221
S	Reel	306075*
T	Locknut	204803
U	Bolt	205167
V	Flat Washer	205055
W	Pawl	404409
	Pawl – “G” Series	404190
X	Spacer	404166
	Spacer – “G” Series	404191
Y	Spring	204363
	Spring – “G” Series	204460
Z	Reel Spacer	207183
AB	Bolt	203161
AC	Reel Spacer	204807
AE	Reel	306062*
AF	Base	404893*
	Base – DLB 800AG	404895*
AG	Spring (optional)	204364

Ref	Description	Part No.
AH	Lockout Lever (optional)	404579
AJ	Spacer (optional)	404166
AK	Gear Cover (optional)	
	Painted Bronze	5240346
	Plated	5240361
AL	Base	404896*
	Base – DLB 1200AG	404897*
AM	Bushing	204009
AQ	Gear Cover (optional)	
	Painted Bronze	5240122
	Plated	5240221
AR	Spacer Washer	204360
AS	Reel	304754*
AS	Reel – 1-7/8” (optional)	304768*
AT	Base	404891*
	Base – DLB 1500AG	404892*
AU	Drive Shaft	304760
AV	Handle – 9-3/8”	5703103
	Handle – 12”	5703111
AX	Reel Spacer	204808
AY	Gear Cover (optional)	
	Painted Bronze	5240387
	Plated	5240403
AZ	Reel	304755*
BA	Base – DLB2500A	406047*
	Base – DLB 2000AG	404899*
BB	Spacer	404434
BC	Bolt	205006
BD	Flat Washer	205139
BE	Intermed. Drive Shaft	306035
BF	Nut	205014
BG	Bolt	204804
BH	Reel	304756*
BJ	Drive Hub (Optional)	304562
BL	Handle Brk. Assy (Opt)	304795
BM	Handle (Optional)	304638
BN	Handle Hub (Optional)	304630
BP	Slotted Nut (Optional)	404970
BQ	“E” Ring	206162
BR	Bushing	206163
BS	Bolt	205335

To order replacement parts contact:

Dutton-Lainson Company

www.dlco.com

Tel: 800-569-6577

Fax: 402-460-4612

e-mail: DLsales@dutton-lainson.com

In Europe Contact:

Aqua-Marine International Ltd.

8 Flanders Parks

Hedge End, Southampton

Hants, England SO30 2FZ

Tel: +44 (0) 1489-776050

Fax: +44 (0) 1489-776055

e-mail: sales@aqua-marineint.co.uk

*Specify Color When Ordering

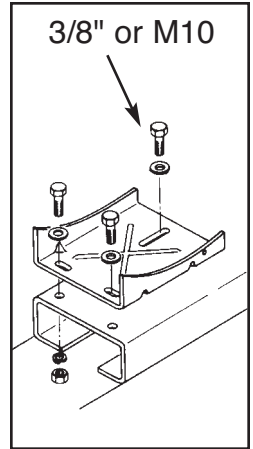
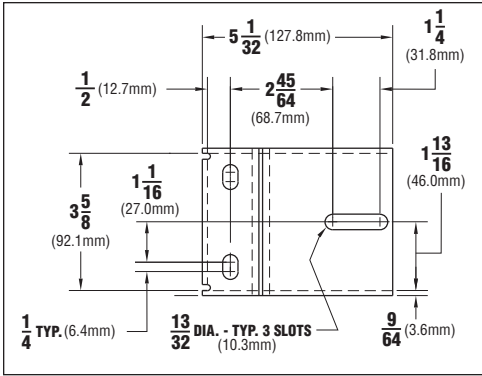

**DLB350A, DLB350AG,
DLB800A, DLB800AG,
DLB1200A, DLB1200AG**

**DLB1500A
DLB1500AG**

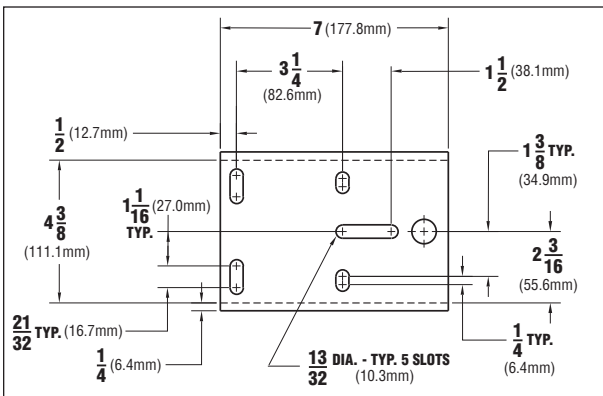
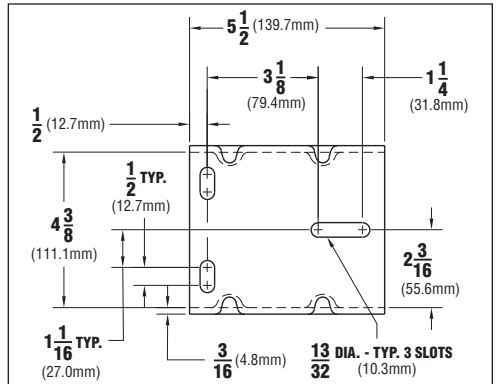

**DLB2000AG
DLB2500A**

-  **WARNING** Component parts should not be interchanged with the component parts of any other Dutton-Lainson model or other manufacturer's winches.
-  **ADVARSEL:** Disse komponentdele må ikke blive udskiftet med komponentdele, der hører til andre modeller fra Dutton-Lainson Company eller til spil af andre fabrikater.
-  **VAROITUS:** Tämän mallin ja muiden Dutton-Lainson Companyn tai muiden valmistajien vintturien osia ei saa vaihtaa keskenään.
-  **WAARSCHUWING:** Deze onderdelen mogen niet verwisseld worden met de onderdelen van andere liermodellen van Dutton-Lainson Company of van lieren van andere fabrikanten.
-  **MISE EN GARDE:** Ces composants ne doivent pas être utilisés de manière interchangeable avec les composants d'aucun autre modèle de Dutton-Lainson Company ou avec les treuils d'un autre fabricant.
-  **ACHTUNG:** Die Komponenten dürfen nicht gegen andere Komponenten anderer Modelle der Dutton-Lainson Company oder der Winden anderer Hersteller ausgetauscht werden.
-  **ATTENZIONE:** Questi componenti non devono essere utilizzati in modo intercambiabile con i componenti di qualsiasi altro modello della Dutton-Lainson Company o con i verricelli di un altro fabbricante.
-  **ADVARSEL:** Disse komponentdelene skal ikke byttes om med komponentdeler for noen annen vinsj verken fra Dutton-Lainson Company eller noen annen produsent.
-  **PRECAUÇÃO:** Esses componentes não devem ser intercambiados com componentes de nenhum outro modelo da Dutton-Lainson Company nem de guinchos de outros fabricantes.
-  **ADVERTENCIA:** No se debe intercambiar estas piezas con las de algún otro modelo de cabrestante de la Dutton-Lainson Company o de otro fabricante.
-  **VARNING:** Byt inte ut komponentdelarna mot komponentdelar från andra vinschar tillverkade av Dutton-Lainson Company eller från andra tillverkares vinschar (eller tvärtom).
-  **ΠΡΟΕΙΔΟΠΟΙΗΣΗ** Αυτά τα συνθετικά μέρη να μην αντικατασταθούν με συνθετικά μέρη άλλου μοντέλου της εταιρίας Δυττον-Λαινσον ή βαρούλκα άλλου εργοστασίου.

ENGLISH-To obtain a copy of the warranty in English, send a self-addressed envelope to: Dutton-Lainson Company; P.O. Box 729; Hastings NE 68902-0729; U.S.A.

DANSK-Man kan få garantibeviset på dansk ved at sende en svarkuvert til: Dutton-Lainson Company, P.O. Box 729, Hastings NE 68902-0729, USA.

SUOMI-Takuutodistuksesta saa suomenkielisen kopion lähettämällä riittävällä postimaksulla ja vastaanottajan osoitteella varustetun kirjekuoren osoitteeseen Dutton-Lainson Company, P.O. Box 729, Hastings NE 68902-0729, USA.

NEDERLANDS-Voor een exemplaar van de garantie in het Nederlands dient u een aan u zelf geadresseerde enveloppe te zenden naar: Dutton-Lainson Company; P.O. Box 729; Hastings NE 68902-0729; U.S.A.

FRANÇAIS-Pour obtenir une copie de la garantie en français, envoyer une enveloppe à votre nom et adresse à : Dutton-Lainson Company; P.O. Box 729; Hastings NE 68902-0729; U.S.A.

DEUTSCH-Wenn Sie eine deutsche Kopie der Garantibestimmungen erhalten möchten, senden Sie bitte einen adressierten Rückumschlag an: Dutton-Lainson Company; P.O.Box 729; Hastings NE 68902-0729; USA

ITALIANO-Per ricevere una copia della garanzia in italiano, inviare una busta riportante il proprio indirizzo a: Dutton-Lainson Company, P.O. Box 729, Hastings NE 68902-0729 USA.

NORSK-En kopi av denne garantien på norsk fås ved å sende en konvolutt med eget navn og adresse, til Dutton-Lainson Company, P.O. Box 729, Hastings NE 68902-0729, USA

PORTUGUÊS-Para obter uma cópia da garantia em português, envie um envelope com a sua morada para: Dutton-Lainson; P. O. Box 729; Hastings NE 68902-0729; E.U.A.

ESPAÑOL-Para obtener una copia de la garantía en español, envíe un sobre con su dirección impresa a: Dutton-Lainson Company, P.O. Box 729; Hastings NE 68902-0729 EE.UU.

SVENSKA-För att erhålla ett exemplar av garantin på svenska skicka ett adresserat kuvert till: Dutton-Lainson Company, P.O.Box 729, Hastings NE 68902-0729 U.S.A.

ΕΛΛΗΝΙΚΑ-Για να λάβετε ένα αντίγραφο της εγγύησης στα Ελληνικά, στείλτε ένα φάκελο εσωκλείοντας τα ταχυδρομικά τέλη αποστολής στην εξής διεύθυνση: Dutton-Lainson Company, P.O.Box 729, Hastings NE 68902-0729 U.S.A..