

INSTRUCTION MANUAL

Operation and Maintenance of TCG-2000

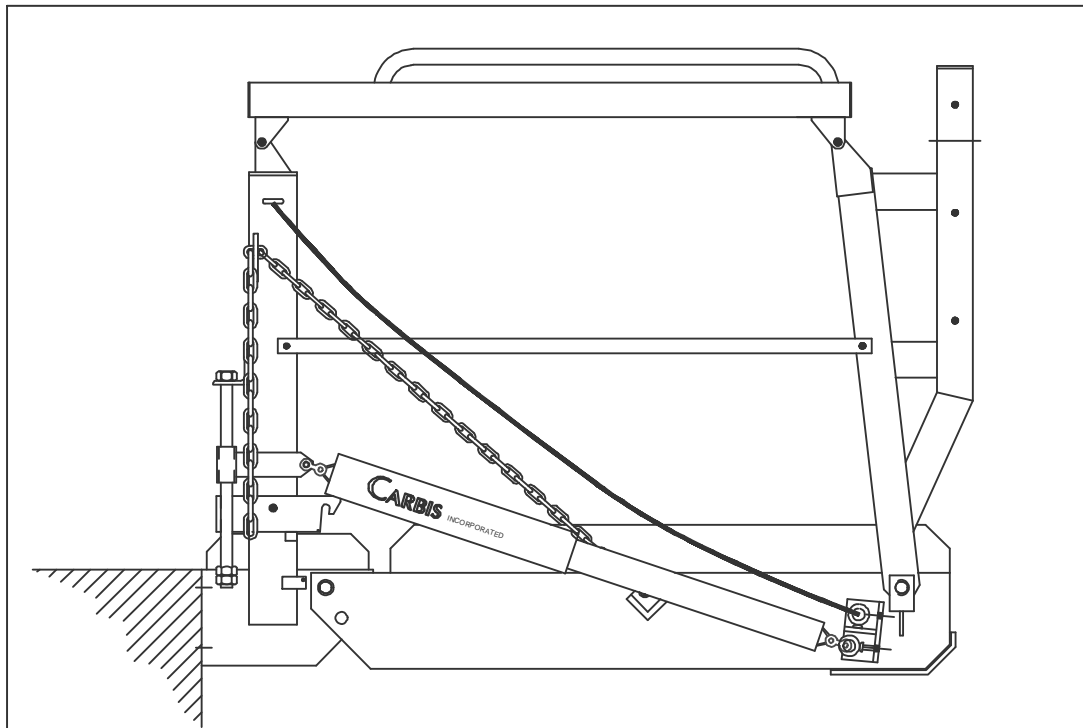

Proven Solutions in Safe Access and
BEYOND

PO Box 6229
Florence, SC 29502-6229
800-845-2387
Fax: (843) 662-1536
Web site: www.carbis.net

TABLE OF CONTENTS

1. Introduction and Safety
2. Product Description
 - 2-1 TCG Track and Carriage (Optional)
 - 2-2 TCG Pivot Mount (Optional)
3. Operation
4. Maintenance
5. Drawings and Specifications
 - 5-1 TCG-2000 Specification 1
 - 5-2 TCG-2000 Specification 2
 - 5-3 TCG Track and Carriage
 - 5-4 TCG Pivot Mount
 - 5-5 TCG Mounting Specifications
- Addenda
 - A-1 TCG Spring Adjustment

INTRODUCTION & SAFETY

Carbis Inc. has stringent Quality Control Standards. This equipment has been thoroughly inspected to ensure these standards have been met. It is highly important that the information contained in this manual be reviewed **BEFORE** installation and/or operation of the unit. Attention should also be given to the following:

- Upon receipt, remove all packaging material and inspect unit for defects caused by shipping and handling. Initial inspection to ensure the fasteners have not loosened due to shipping is necessary. All factory installed fasteners have been tightened and done so to remain tight. It is imperative that any loose fasteners be tightened prior to installation of the equipment. **ALL** fasteners, including those installed in the field, should be periodically checked and tightened if needed.
- Personnel Protective Equipment (PPE) (i.e. gloves, safety glasses, safety shoes, etc...) specified by OSHA regulations should be worn at all times during operation of this equipment.
- Before actuation of the unit, always ensure that the area is free of obstructions and that no personnel will come in contact with the moving parts of the equipment.
- Only qualified¹ personnel should be permitted to operate the equipment.
- Check that all: warning, caution, safety placards (inc. signs, decals) are clearly visible, legible, and in good repair.

WARNING: This unit is conductive to electricity. Any grounding that may be required is the responsibility of your company and should be performed in accordance with local, State, Federal codes.

ATTENTION: To avoid problems associated with stainless steel bolts: (1) Keep nuts and bolts free of grime and other contaminants that may get into threads. (2) Lubricate stainless steel bolts and nuts prior to tightening. (3) Avoid the use of impact wrenches at high speed. Lower the speed, as this will allow heat to dissipate as the connection is tightened.

1- Properly trained, physically capable

DESCRIPTION

TCG-2000

Reference Specification 1 pg. 5-1 and Specification 2 on pg. 5-2

The TCG-2000 Series is a fixed surface articulating gangway. This unit can be mounted directly to a platform in a fixed position, pivot mounted which allows 10 degrees of rotation each side of center, and/or track mounted which allows the gangway to be used in different locations along the platform.

- The self-leveling fixed surface ensures reliable access to equipment at low angles relative to the access surface. Carefully designed to allow 30 degrees of useful range while maintaining the integrity of the unit.
- Bumpers mounted on the bottom leading edge of the stringers give added protection against vehicle damage.
- A foot-lock mounted on the base tread prevents unwanted deployment and stores the unit in the upright position.
- The normal working range of the TCG-2000 is 15 degrees above and 15 degrees below horizontal. Adjustable chains attached to the stringers and supported by the base tread uprights hold the gangway in any desired position within the normal working range. The chains add strength and stability to the equipment while allowing a variety of vehicles to be accessed.
- Covered springs attach the base tread uprights to the stringers and provide adjustable tension to compensate for the weight of the gangway. This minimizes the amount of force necessary to actuate the gangway.
- A pull-rope aids in the return of the gangway to the upright stored position, typically 85 degrees above horizontal.
- The outboard uprights of the gangway support the outer end of the top handrails and midrails, and serve as a support for optional safety cages.

! ATTENTION! If the gangway purchased has an auxiliary and/or mechanical source of power, refer to the included manuals for further information concerning the power equipment including: Description, Installation, Operation, and Maintenance.

OPTIONAL TCG TRACK AND CARRIAGE **DESCRIPTION**

Reference TCG – Track & Carriage Illustration pg. 5-3

The track and carriage system allows the user to move the access equipment attached to different locations along the face of the platform. The track is mounted to the face of the platform and the access equipment is mounted directly the carriage.

- Each track section is roll formed into a modified C-shape that provides the maximum number of contact surfaces for the carriage assembly. Numerous Tracks may be installed end to end.
- A stop rod is inserted through holes located at each end of the track. This traps the carriage, preventing the carriage from traveling beyond the stop rod.
- The carriage assembly consists of a series of welded plates designed to support the rollers that counteract forces produced by the gangway and its' use.
- There are a minimum of 2 load bearing rollers supporting forces in any one direction. These rollers allow the access equipment to be positioned at any point along the track.

! ATTENTION! If the gangway purchased has an auxiliary and/or mechanical source of power, refer to the included manuals for further information concerning the power equipment including: Description, Installation, Operation, and Maintenance.

OPTIONAL TCG PIVOT MOUNT **DESCRIPTION**

Reference TCG – Pivot Mount Illustration pg. 5-4

The pivot mount option consists of a modified gangway base tread which has a pivot post mounted on the underside. An extension plate is attached to the platform side of the base tread to close any gaps created by the pivot.

- The pivot mount and receiver sleeve are one unit. The receiver bracket can be mounted to the face of the platform (i.e. bolted, welded) or modified to mount specific to most applications.
- The range of pivot rotation is 10 degrees each side of center.
- Once installed the pivot post is allowed to rotate freely inside the receiver sleeve, and rests on a wear pad to prevent damage to either side of the system.
- There are optional pivot systems available that retrofit our system to an existing pivot support system.

OPERATION

ATTENTION: The gangway should be kept in its stored position when not in use and prior to spotting any vehicle.

The normal operating range for a TCG-2000 is from 15 degrees below horizontal to 15 degrees above horizontal. The chain stop feature allows adjustment to be made within the operating range and also will allow one man to access vehicles without the equipment and vehicle coming in contact.

1. Spot the vehicle and/or the work area directly in front of the gangway. (Note: For pivoted or track mounted gangways; spot vehicles within the working limits of the equipment. Then pivot or roll the gangway to the desired position.)
2. With the chain stops in the next to the last link, depress the foot lock pedal. This will allow the gangway to be deployed from its 85 degree stored position.
3. While depressing the foot lock place both hands on the top handrail and push outward.
4. After the gangway is positioned, adjust the chain supports so that both chains equally support the gangway.
5. After performing the required work on the vehicle, use the pull-up rope to return the gangway to its stored position. It is not necessary to depress the foot lock pedal when raising the gangway; however, make sure that the foot lock has engaged the bolt on the right side of the gangway.
6. Return the chains to the next to last link location for the next operator.

CAUTION: To reduce the risk of injury, keep hands clear of chains and mating parts while operating the gangway.

!!WARNING!!

Correct vehicle positioning and proper deployment of Carbis equipment is imperative to its function. Incorrectly positioned vehicles or improper use of this equipment increases the risk of injury and/or death. Carbis equipment is designed to function only as described in the manual and depicted on the drawing. **It is the sole responsibility of the owner to**

ensure proper use of Carbis Equipment.

MAINTENANCE

1. Visually inspect the unit before each use. Replace any damaged parts. A full inspection of the unit once per month is a recommended minimum. Harsh environments and/or heavy use may dictate more frequent inspections and lubrication.
- 2 All fastening hardware that has been factory installed has been done so to remain tight; if any fastening hardware, whether factory or field installed, has been loosened, it is imperative that it be tightened before the use of the equipment.
- 3 Lubricate the pivot points on the handrails and main body with lightweight aerosol oil.
- 4 Some units have flanged bearings with a grease fitting. These bearings should be lubricated with lithium based grease.
5. To adjust spring tension, see attached drawing titled "Spring Adjustment".
6. Inspection of springs should include, but not limited to, a check of the number of coils wound around the spring clip on each end. A minimum of two full coils is required.

For assistance with: replacement parts, comments, or questions. Please contact Carbis' Customer Service Department at 1-800-845-2387. To help us better serve you, please have your model number and serial number available.

TCG-2000 SPECIFICATION 1

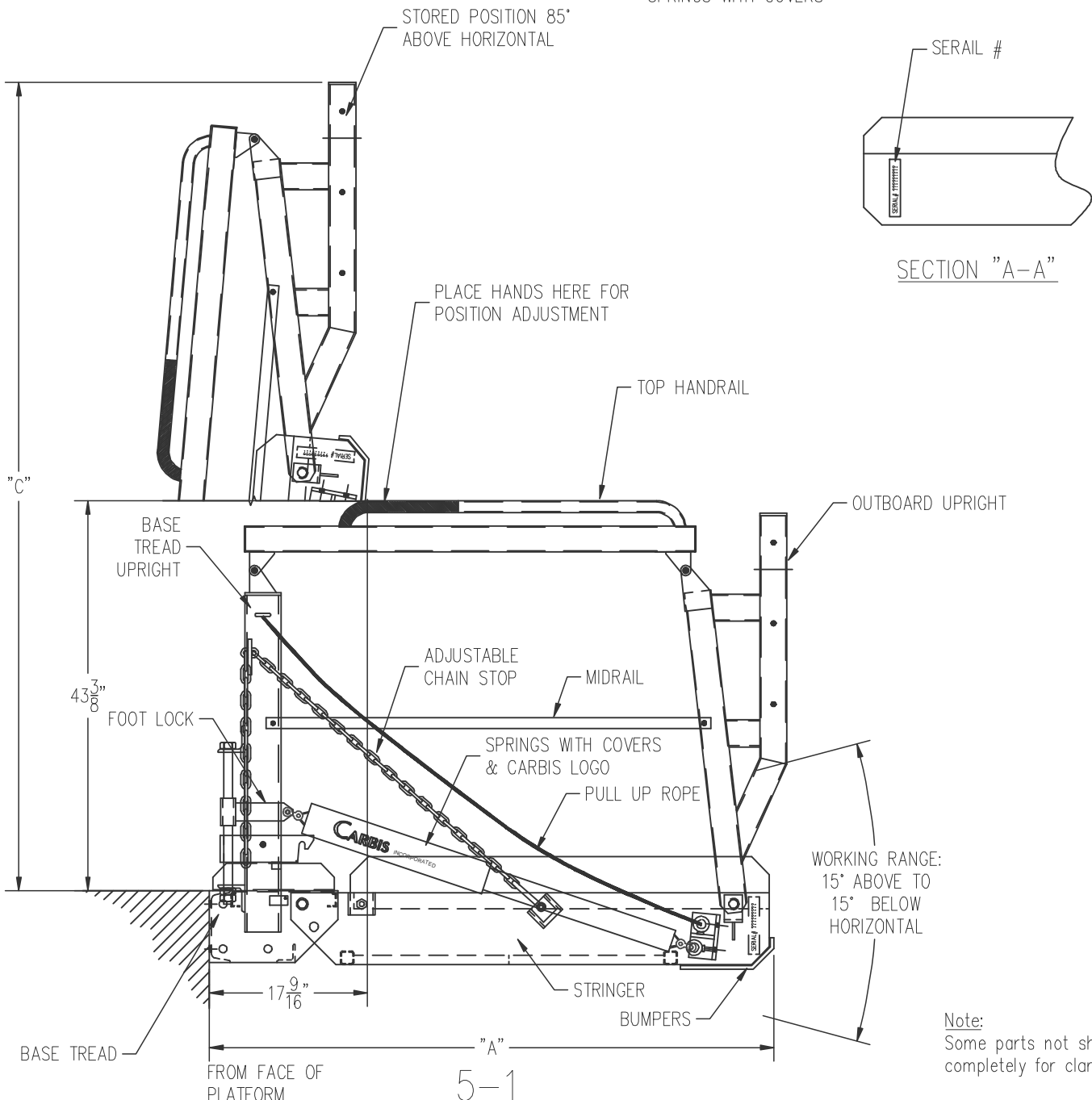
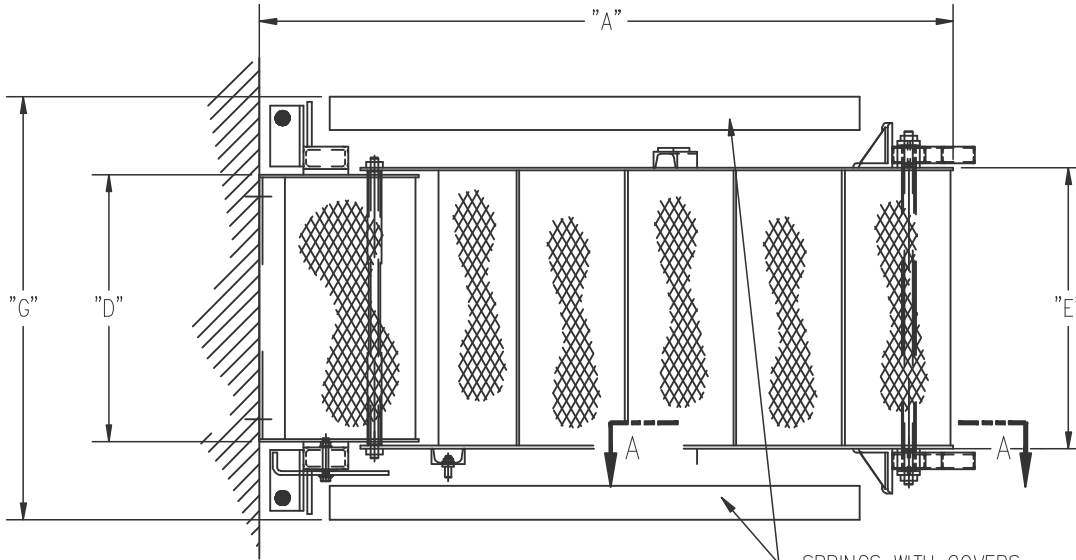

Note:
Some parts not shown completely for clarity.

TCG-2000 SPECIFICATION 2

MODEL NO.	A	C
TCG-2000-3	39"	66"
TCG-2000-4	51"	78"
TCG-2000-5	63"	90"
TCG-2000-6	75"	102"
TCG-2000-7	87"	114"
TCG-2000-8	99"	126"

Sample Model Number:
TCG-2000-7-A

WIDTH	D	E	G
-A	24"	25 1/4"	38"
-AN	18 1/4"	20"	32 1/4"
-WA	44"	45 1/4"	58"

All optional mounting angels for all gangways are made of steel.

NOTE: The "A" in the width column determines the material of the gangway. The "A" may be changed to "P", "G", or "S", depending on the material required. See material options for symbols.

SPECIFICATIONS AND OPTIONS

- Walk surface options:
Open Metal Plank
Fiberglass Grating
Bar Grating

- Material Options
S = Mill Steel
P = Primed Steel
G = Galvanized Steel
A = Aluminum

- Counterbalance Options:
Springs (standard)
Hydraulic (optional)
Pneumatic (optional)

Note: Depending on the size of the gangway and options purchased, standard spring counterbalance may not be available for that gangway.

- All aluminum gangways will have galvanized steel base treads
- Automatic lock in at the 85 degree stored position
- Padded lower edge prevents vehicle damage
- For mounting options, see the mounting option specification sheet (Vertical mount shown for reference only)

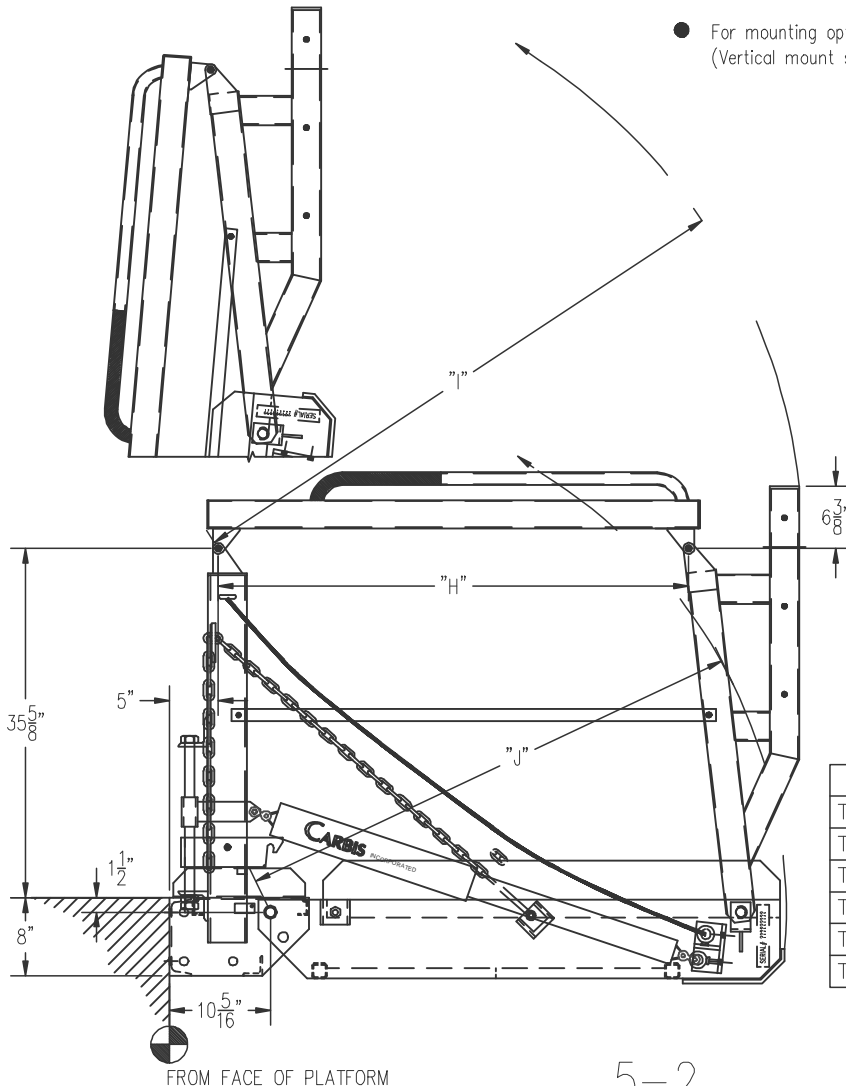

LOAD CAPACITY
FIXED MOUNT: 500 LBS
PIVOT MOUNT: 500 LBS
TRACK MOUNT: 500 LBS

The TCG-2000 gangway meets or exceeds OSHA regulations as we interpret them.

MODEL NO.	H	I	J
TCG-2000-3	24"	35 3/8"	28 1/4"
TCG-2000-4	36"	47 3/8"	40 1/4"
TCG-2000-5	48"	59 3/8"	52 1/4"
TCG-2000-6	60"	71 3/8"	64 1/4"
TCG-2000-7	72"	83 3/8"	76 1/4"
TCG-2000-8	84"	95 3/8"	88 1/4"

TCG—TRACK & CARRIAGE

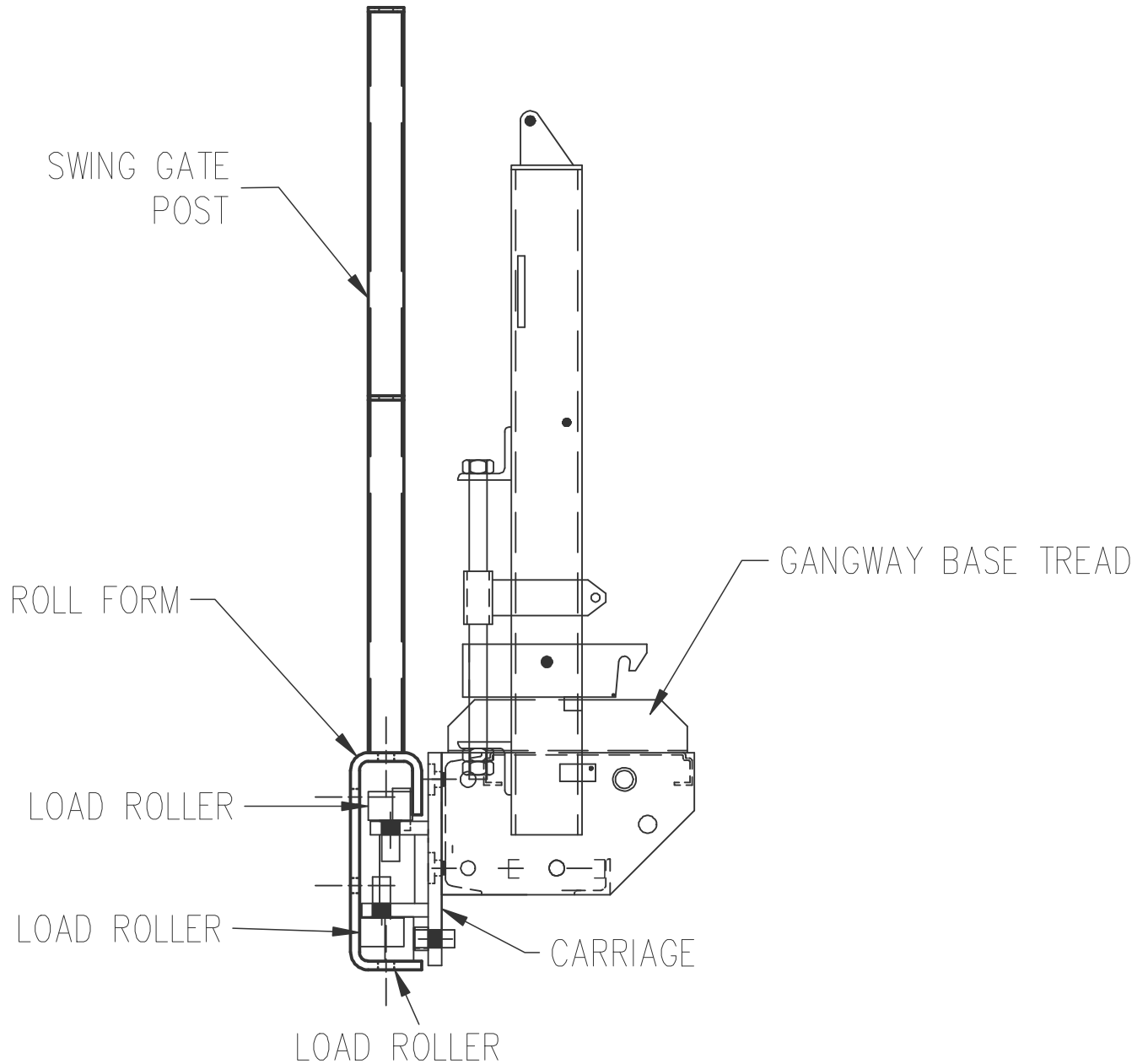

STOP RODS AT EACH END
PREVENT CARRIAGE FROM
COMING OUT OF TRACK
(NOT SHOWN)

TCG-PIVOT MOUNT

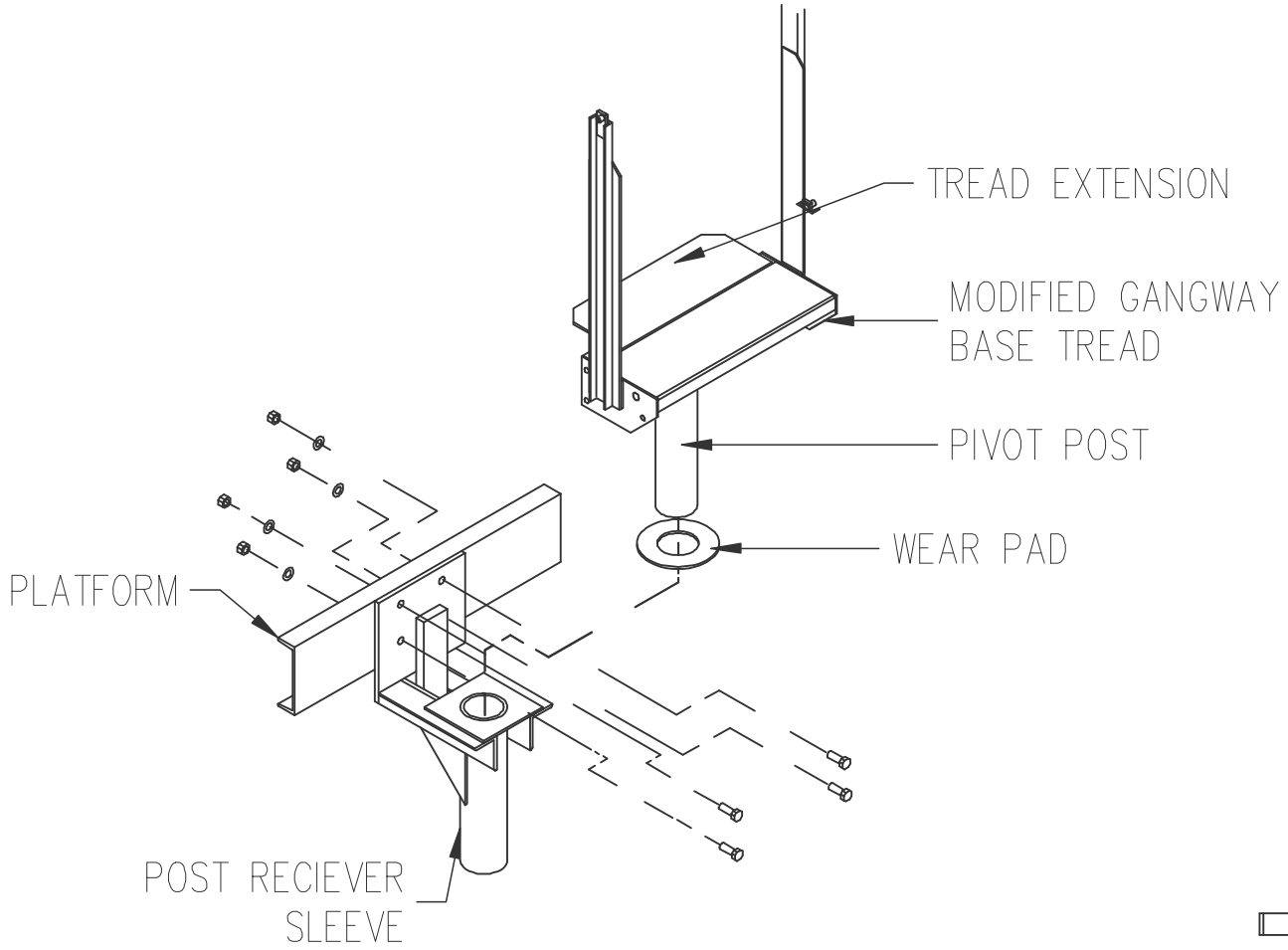

FACE MOUNT

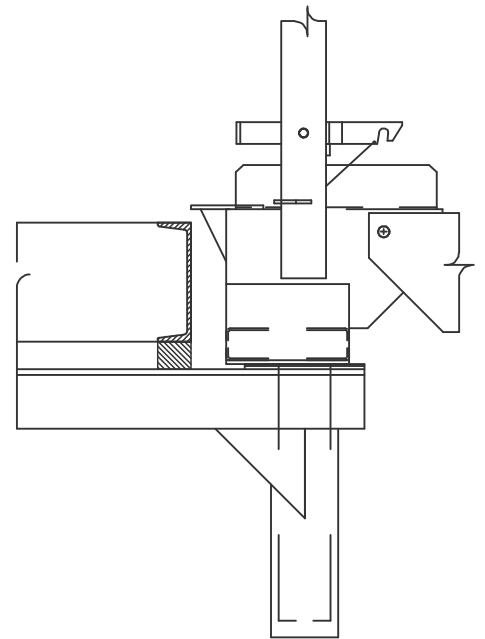

UNDERSLUNG MOUNT

TCG-MOUNTING SPECIFICATION

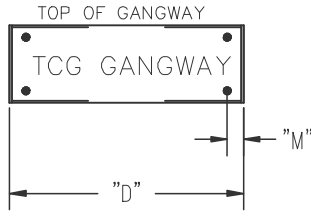

VERTICAL MOUNT
(Standard)

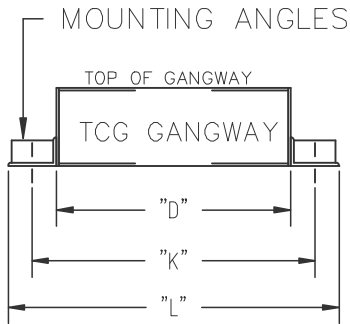

OPTIONAL
Horizontal Mount

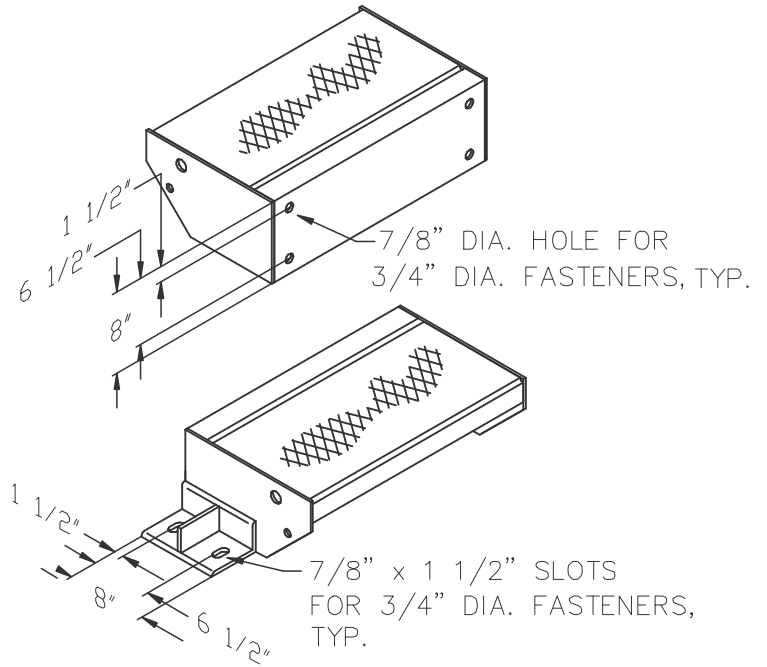

MODEL NUMBER	WIDTHS											
	-A				-AN				-WA			
	D	K	L	M	D	K	L	M	D	K	L	M
TCG-1000	24"	31"	34"	2"	18 1/4"	25 1/4"	28 1/4"	2"	44"	51"	54"	3 1/4"
TCG-2000	24"	31"	34"	2"	18 1/4"	25 1/4"	28 1/4"	2"	44"	51"	54"	3 1/4"
TCG-2500	24"	31"	34"	2"	18 1/4"	25 1/4"	28 1/4"	2"	44"	51"	54"	3 1/4"

Note:

The "A" in the width column determines the material of the gangway. The "A" may be changed to "P", "G", or "S", depending on the material required. See material chart for symbols.

Material Chart

- S = Mill Steel
- P = Primed Steel
- G = Galvanized Steel
- A = Aluminum

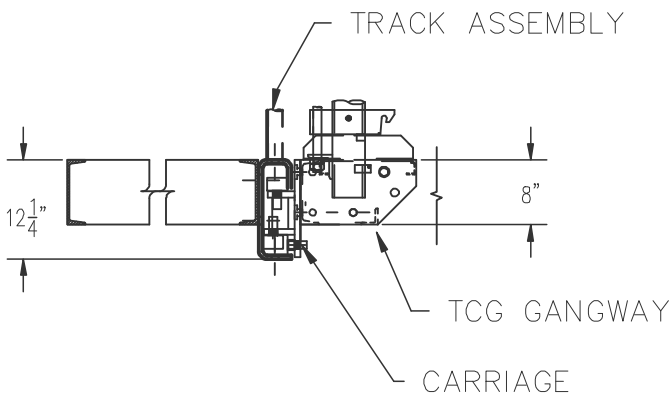

OPTIONAL TRACK MOUNT
See drawing TCG-Track & Carriage

For overall length of gangway, at horizontal position, add 5 1/8" to the "A" dimension on the TCG specification sheet.

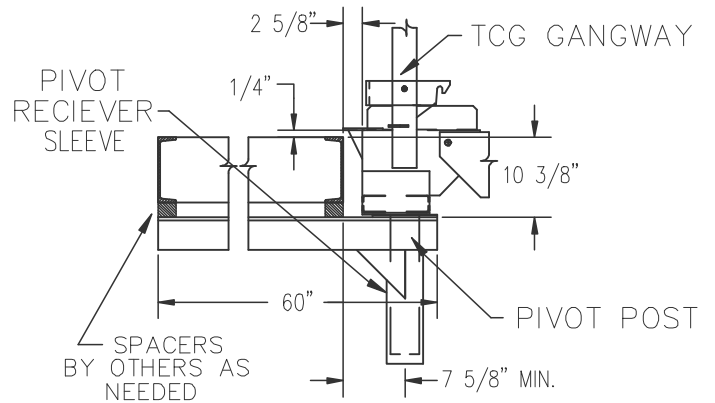

OPTIONAL PIVOT MOUNT
See drawing TCG-Pivot

For overall length of gangway, at horizontal position, add 2 5/8" to the "A" dimension on the TCG specification sheet. 60" length for female pivot can be trimmed to shorter length if required.

TCG-2000 SPRING ADJUSTMENT

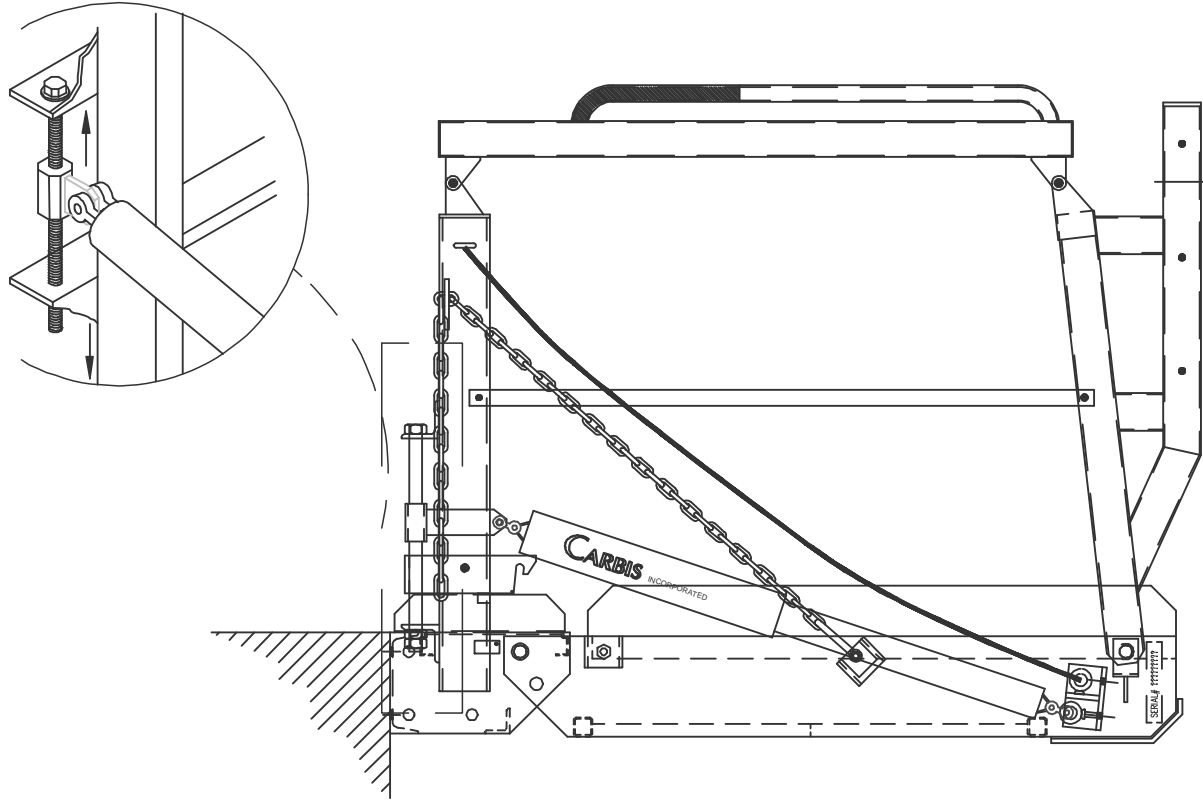

Adjustment to the spring counterbalance system may be required to change the amount of force necessary for the return of the gangway to the stored position. The springs are set at the factory for the gangway weight and any options that might have been purchased. These could include a seatainer end tread and/or a cage. It is necessary for all purchased options to be installed prior to use for the springs to function properly.

Spring Adjustment

Large movement of the spring is seldom the solution for spring adjustment. Adjustments in $\frac{1}{2}$ " increments and checking the balance by operating the gangway is normally enough to bring the unit into the specified pull on the rope of 50 pounds or less. Marking and/or measuring the starting location is important in saving time and not repeating a prior location.

Symptom and Cure

The following adjustments should only be made with the gangway in the stored position and the foot lock engaged. The bolt should be turned with the proper size wrench. The head of the bolt should be turned; do not attempt to loosen the double jam unit. If the gangway is hard to lift from the working position....raise the ear. If the gangway will not stay down in working position....lower the ear. Again it should only take a few $\frac{1}{2}$ " incremental changes to fine-tune your unit.

Spring Replacement

If the gangway requires any component of the spring counterbalance system replaced, you must follow the procedure below. If, at any time, you do not fully understand the procedure, call Carbis and ask for technical assistance.

- 1) With the gangway in the stored position, tie the unit off
- 2) Mark the current ear location on the threaded rod
- 3) Relieve all tension on the spring by raising the spring ear
- 4) At this point, follow replacement instructions supplied with the spring counterbalance system
- 5) Reconnect hardware as instructed
- 6) Relocate the ear in original position
- 7) Untie the gangway and test unit
- 8) If adjustments are required, see Symptom and Cure